

Earth-Moon-Earth (EME)

EME communication, also known as *moonbounce*, has become a popular form of amateur space communication. The concept is simple: the moon is used as a passive reflector for two-way communication between two locations on Earth (see Figure 30.1). With a total path length of about half a million miles, EME may be considered the ultimate DX. Very large path losses suggest big antennas, high power, and the best low noise receivers; however, the adoption of modern coding and modulation techniques can significantly reduce these requirements from their levels of just ten years ago. Even so, communication over the EME path presents unusual station design challenges and offers special satisfaction to those who can meet them. EME is a natural and passive propagation phenomenon, and EME QSOs count toward WAC, WAS, DXCC and VUCC awards. EME opens up the bands at VHF and above to a new frontier of worldwide DX.

Professional demonstrations of EME capability were accomplished shortly after WW II. Amateurs were not far behind, with successful reception of EME echoes in 1953 and pioneering two-way contacts made on the 1296, 144, and 432 MHz bands in the 1960s. Increased EME activity and advances to other bands came in the 1970s, aided by the availability of reliable low-noise semiconductor devices and significant improvements in the design of Yagi arrays and feed antennas for parabolic dishes. These trends accelerated further in the 1980s with the advent of GaAsFET and HEMT preamplifiers and computer-aided antenna designs, and again after 2000 with the introduction of digital techniques. EME QSOs have been made on all amateur bands¹ from 28 MHz to 47 GHz, and many operators have made WAC, WAS, and even DXCC on one or more of the VHF and UHF bands. EME is now within the grasp of most serious VHF and UHF operators.

EME PROPAGATION

Path Loss

Path loss in free space is caused by nothing more than the spherical expansion of a radio wave as it propagates away from an antenna. An EME signal is attenuated as $1/d^2$ (inverse distance squared) over the quarter-million mile path to the moon, and again as $1/d^2$ on the return trip, for a net $1/d^4$ path loss. Radio waves incident on the surface of the moon are often said to be “reflected,” although in fact they are partly absorbed and partly scattered by the irregular lunar surface. A full expression giving the EME path loss as a ratio of received power to transmitted power, assuming isotropic antennas at each end of the path, is

$$l = \frac{\eta r^2 \lambda^2}{64 \pi^2 d^4} \quad (1)$$

where r is the radius of the moon, λ the wavelength, d the distance to the moon, and η the lunar reflection coefficient. In this section we use the convention of lower-case letters to denote dimensionless ratios, and the corresponding upper-case letters to give equivalent values in dB. Thus, the EME path loss in dB is given for isotropic antennas by the expression

$$L = 10 \log l = 10 \log \left(\frac{\eta r^2 \lambda^2}{64 \pi^2 d^4} \right). \quad (2)$$

Inserting values $r = 1.738 \times 10^6$ m, $d = 3.844 \times 10^8$ m, and $\eta = 0.065$ gives the average path losses quoted in Table 30.1 for the principal amateur EME bands. The need to overcome these very large attenuations is of course the main reason why EME is so challenging. The moon's orbit is an ellipse, and its distance d varies by $\pm 6.8\%$ over each month. Because of the inverse-fourth-power law in Equations (1) and (2), this change results in path-loss variations of ± 1.1 dB at the extremes of lunar distance, independent of frequency. The reflection of radio waves is of course not affected by the optical phases of the moon.

The dependence of path loss on λ^2 suggests that EME should be nearly 20 dB more difficult at 1296 MHz than at 144 MHz. This conclusion is misleading, however, because of the assumption of isotropic antennas. If one uses transmitting and receiving antennas of gain g_t and g_r , expressed as ratios, the expected power p_r received as a lunar echo may be written as the product

$$p_r = p_t g_t g_r l \quad (3)$$

where p_t is the transmitted power. The standard expression for an antenna's power gain is $g = 4\pi A / \lambda^2$, where A is the *effective aperture* or *collecting area*. Gain in dBi (dB over an isotropic antenna) may therefore be written as $G = 10 \log (4\pi A / \lambda^2)$. With P_r and P_t expressed in dB relative to some reference power, for example 1 W, we have

$$P_r = P_t + G_t + L + G_r. \quad (4)$$

Thus if one assumes a fixed size of antenna, such as a parabolic dish or Yagi array of effective frontal area A , the frequency dependence is reversed: for a given transmitted power, lunar echoes would be 20 dB stronger for every decade increase in frequency, rather than 20 dB weaker. Most practical situations fall somewhere between these two extremes of frequency dependence. For reasons explained in detail below, amateur EME communication is feasible with roughly comparable degrees of difficulty over nearly two decades of frequency, from

144 MHz to 10 GHz. Not surprisingly, some very different techniques must be mastered in order to do successful EME at the lower and upper extremes of this wide frequency range — so the final choice of band(s) for EME is often determined by the interests, skills, and resources of an individual operator.

Echo Delay and Time Spread

Radio waves propagate at speed c , the speed of light, very nearly equal to 3×10^8 m/s. Propagation time to the moon and back is therefore $2d/c$ or about 2.4 s at perigee, 2.7 s at apogee, and 2.56 s on average. The moon is nearly spherical, and its radius corresponds to $r/c = 5.8$ ms of wave travel time. The trailing parts of an echo, reflected from irregular surface features near the edge of the lunar disk, are delayed from the leading edge by as much as twice this value. In practice, most of the moon's surface appears relatively smooth at the radio wavelengths used for amateur EME. Lunar reflections are therefore quasi-specular, like those from a shiny ball bearing, and the power useful for communication is mostly reflected from a small region near the center of the disk. The effective *time spread* of an echo amounts to no more than 0.1 ms.

Reflection from a smooth surface preserves linear polarization and reverses the sense of circular polarization. At shorter wavelengths the lunar surface appears increasingly rough, so reflections at 10 GHz and above contain a significant diffuse component as well as a quasi-specular component. The diffuse component is depolarized, and significant portions of it arise from regions farther out toward the lunar rim. The median time spread can then be as much as several milliseconds. In all practical cases, however, time spreading is small enough that it does not cause significant smearing of CW keying or inter-symbol interference in the slowly keyed modulations commonly used for digital EME.

Time spreading does have one very significant effect. Signal components reflected from different parts of the lunar surface travel different distances and arrive at Earth with random phase relationships. As the relative geometry of the transmitting station, receiving station, and reflecting lunar surface changes, signal components may sometimes add and sometimes cancel, creating large amplitude fluctuations. Often referred to as *libration fading*, these amplitude variations will be well correlated over a *coherence bandwidth* of a few kHz, the inverse of the time spread.

Doppler Shift and Frequency Spread

EME signals are also affected by Doppler shifts caused by the relative motions of Earth and moon. Received frequencies may be higher or lower than those transmitted; the shift is proportional to frequency and to the rate of change of total path length from transmitter to receiver. The velocities in question are usually dominated by the Earth's rotation, which at the equator amounts to about 460 m/s. For the self-echo or "radar" path, frequency shift will be maximum and positive at moonrise, falling through zero as the moon crosses the local meridian (north-south line) and a maximum negative value at moonset. The magnitude of shifts depends on station latitude, the declination of the moon, and other geometrical factors. For two stations at different geographic locations the mutual Doppler shift is the sum of the individual (one-way) shifts. Maximum values are around 440 Hz at 144 MHz, 4 kHz at 1296 MHz, and 30 kHz at 10 GHz.

Just as different reflection points on the lunar surface produce different time delays, they also produce different Doppler shifts. The moon's rotation and orbital motion are synchronized so that approximately the same face is always toward Earth. The orbit is eccentric, so the orbital speed varies; since the rotation rate does not vary, an observer on Earth sees an apparent slow "rocking" of the moon, back and forth. Further aspect changes are caused by the 5.1° inclination between the orbital planes of Earth and moon. The resulting total line-of-sight velocity differences are around 0.2 m/s, causing a *frequency spread* of order 0.2 Hz at 144 MHz. Like all Doppler effects, these shifts scale with frequency. However, measured values of frequency spread increase slightly more rapidly than frequency to the first power because a larger portion of the lunar surface contributes significantly to echo power at higher frequencies. Linear scaling would suggest frequency spread around 15 Hz at 10 GHz, but measurements show it to be several times larger.

From a communication engineering point of view, libration fading is just another example of the so-called *Rayleigh fading* observed on any radio channel that involves multiple signal paths — such as ionospheric skywave, tropospheric scatter, and terrain multipath channels with reflections from buildings, trees, or mountains. Interference effects that cause signal fading depend on frequency spread as well as time spread. Signal amplitudes remain nearly constant over a *coherence time* given by the inverse of frequency spread. In general, fading rates are highest (shortest coherence times) when the moon is close to the local meridian and lowest near moonrise and moonset. They also depend on the moon's location in its elliptical orbit. Typical

coherence times are several seconds at 144 MHz, a few tenths of a second at 1296 MHz, and 20 ms at 10 GHz. At 144 MHz, intensity peaks lasting a few seconds can aid copy of several successive CW characters, but at 432 MHz the timescale of peaks and dropouts is closer to that of single characters. At 1296 MHz the fading rates are often such that CW characters are severely chopped up, with dashes seemingly converted to several dots; while the extremely rapid fading at 10 GHz gives signals an almost “auroral” tone. Skilled operators must learn to deal with such effects as best they can. As described further below, modern digital techniques can use message synchronization as well as error-correcting codes and other diversity techniques to substantially improve the reliability of copy on marginal, rapidly fading EME signals.

Atmospheric and Ionospheric Effects

Propagation losses in the Earth’s troposphere are negligible at VHF and UHF, although rain attenuation can be an important factor above 5 GHz. Tropospheric ducting of the sort that produces enhanced terrestrial propagation can bend signals so that the optimum beam heading for EME is directed away from the moon’s center. Even under normal conditions, enough refraction occurs to allow radio echoes when the moon is slightly below the visible horizon. In practice, these problems are usually overshadowed by other complications of doing EME at very low elevations, such as blockage from nearby trees or buildings, increased noise from the warm Earth in the antenna’s main beam, and man-made interference.

The Earth’s ionosphere causes several propagation effects that can be important to EME. These phenomena depend on slant distance through the ionospheric layer, which increases at low elevations. At elevation 10°, attenuation through the daytime ionosphere is generally less than 0.5 dB at 144 MHz, and nighttime values are at least 10 times lower. These numbers scale inversely as frequency squared, so ionospheric absorption is mostly negligible for EME purposes. Exceptions can occur at 50 MHz, and under disturbed ionospheric conditions at higher frequencies. Ionospheric refraction can also be important at 50 MHz, at very low elevations. Ionospheric scintillations (analogous to the “twinkling” of stars in the Earth’s atmosphere) can exhibit significant effects at VHF and UHF, primarily on EME paths penetrating the nighttime geomagnetic equatorial zone or the auroral regions. Again, disturbed ionospheric conditions magnify the effects. The multipath time spread is very small, less than a microsecond, while frequency spread and fading rate can be in the fractional hertz to several hertz range. These scintillations can increase the fading rates produced by Earth rotation and lunar librations.

Much more important is the effect of Faraday rotation in the ionosphere. A linearly polarized wave will see its plane of polarization rotate in proportion to the local free-electron density, the line-of-sight component of the Earth's magnetic field, and the square of wavelength. The effect is therefore greatest during the daytime, for stations well away from the equator, and at low frequencies. A mismatch $\Delta\theta$ between an incoming wave's polarization angle and that of the receiving antenna will attenuate received signal power by an amount $\cos^2\Delta\theta$. As shown in Figure 30.2, polarization losses increase rapidly when the misalignment exceeds 45° . Because of the λ^2 dependence, Faraday rotation is generally important for EME operation only at 432 MHz and below. The effect is cumulative for an outgoing signal and its returning echo, so a station transmitting and receiving with the same linearly polarized antenna will see its own echoes disappear whenever the total Faraday rotation is close to an odd integral multiple of 90° . Faraday rotation in the daytime ionosphere can amount to as much as a full turn at 432 MHz and many turns at 144 MHz. At 432 MHz the rotation may be essentially constant over several hours; on lower bands significant changes can occur in 30 minutes or less. Variations are especially noticeable near sunrise or sunset at one end of the path, where ionization levels are changing rapidly.

The Earth's spherical shape determines the orientation in space of a wave emitted or received by an antenna with horizontal (or other locally referenced) polarization angle. As discussed in detail below, when combined with Faraday rotation this effect can cause users of fixed-polarization antennas to experience apparent one-way propagation.

A polarized radio signal reflected from the moon's rough surface is partially scattered into other polarization states, and a disturbed ionosphere can sometimes generate a mixture of polarization angles. As a consequence, fading caused by 90° polarization misalignments will not always produce deep nulls. Measurements show that at UHF and below, the cross-polarized scattered signal is usually 15 dB or more below the principal polarization. On the other hand, at 10 GHz and higher, where the lunar surface is much rougher in terms of wavelength, cross-polarized diffuse echoes may be only a few dB below the principal reflected polarization. These comments apply to both linear and circular polarization.

FUNDAMENTAL LIMITS

Background Noise

EME signals are always weak, so considerations of signal-to-noise ratio are paramount. A received signal necessarily competes with noise generated in the receiver as well as that picked

up by the antenna, including contributions from the warm Earth, the atmosphere, the lunar surface, the diffuse galactic and cosmic background, and possibly the sun and other sources. (Refer to Figure 30.1, and think of adding a warm atmosphere just above the Earth, the sun somewhere beyond the moon, and galactic and extragalactic noise sources at even greater distances, filling the whole sky.). If P_n is the total noise power collected from all such noise sources expressed in dBW, we can write the expected signal-to-noise ratio of the EME link as

$$SNR = P_r - P_n = P_t + G_t + L + G_r - P_n. \quad (5)$$

Since isotropic path loss L is essentially fixed by choice of a frequency band (Table 30.1), optimizing the signal-to-noise ratio generally involves trade-offs designed to maximize P_r and minimize P_n — subject, of course, to such practical considerations as cost, size, maintainability, and licensing constraints.

It is convenient to express P_n in terms of an equivalent system noise temperature T_s in kelvins (K), the receiver bandwidth B in Hz, and Boltzmann's constant $k = 1.38 \times 10^{-23} \text{ J K}^{-1}$:

$$P_n = 10 \log(kT_s B). \quad (6)$$

The system noise temperature may in turn be written as

$$T_s = T_r + T_a. \quad (7)$$

Here T_r is receiver noise temperature, related to the commonly quoted noise figure NF in dB by

$$T_r = 290(10^{0.1NF} - 1). \quad (8)$$

Antenna temperature T_a includes contributions from all noise sources in the field of view, weighted by the antenna pattern. The lunar surface has a temperature around 210 K; since most antennas used for amateur EME have beamwidths greater than the moon's angular size, as well as sidelobes, the moon's effect will be diluted and noise from other sources will also be received. Sidelobes are important, even if many dB down from the main beam, because their total solid angle is large and therefore they are capable of collecting significant unwanted noise power.

At VHF the most important noise source is diffuse background radiation from our Galaxy, the Milky Way. An all-sky map of noise temperature at 144 MHz is presented in the top panel of Figure 30.3. This noise is strongest along the plane of the Galaxy and toward the galactic center. Galactic noise scales as frequency to the -2.6 power, so at 50 MHz the temperatures in Figure 30.3 should be multiplied by about 15, and at 432 divided by 17. At 1296 MHz and above galactic noise is negligible in most directions. During each month the moon follows a right-to-left path lying close to the ecliptic, the smooth solid curve plotted in Figure 30.3. Sky background temperature behind the moon therefore varies approximately as shown in the lower

panel of Figure 30.3, regardless of geographical location on Earth. For about five days each month, when the moon is near right ascension 18 hours and declination -28° , VHF sky background temperatures near the moon are as much as ten times their average value, and conditions for EME on the VHF bands are poor.

By definition the sun also appears to an observer on Earth to move along the ecliptic, and during the day solar noise can add significantly to P_n if the moon is close to the sun or the antenna has pronounced sidelobes. At frequencies greater than about 5 GHz the Earth's atmosphere also contributes significantly. An ultimate noise floor of 3 K, independent of frequency, is set by cosmic background radiation that fills all space. A practical summary of significant contributions to system noise temperature for the amateur bands 50 MHz through 24 GHz is presented in Table 30.2 and Figures 30.4 and 30.5, discussed in the next section.

Antenna and Power Requirements

The basic circumstances described so far ensure that frequencies from 100 MHz to 10 GHz are the optimum choices for EME and space communication. Over this region and a bit beyond, a wide variety of propagation effects and equipment requirements provide a fascinating array of challenges and opportunities for the EME enthusiast. The enormous path-loss variability encountered in terrestrial HF and VHF propagation does not occur in EME work, and some of the remaining, smaller variations — for example, those arising from changing lunar distance and different sky background temperatures — are predictable. We can therefore estimate with some confidence the minimum antenna sizes and transmitter powers required for EME communication on each amateur band.

The necessary information for this task is summarized in Table 30.2 and Figures 30.4 and 30.5. Columns 2 through 6 of the table give typical contributions to system noise temperature from the cosmic microwave background (CMB), the Earth's atmosphere, the warm surface of the moon, galactic noise entering through the main antenna beam, and sky and ground noise from an antenna's side and rear lobes. Antenna temperature T_a is a combination of all these contributions, appropriately weighted by antenna pattern; the system noise temperature T_s is then the sum of T_a and receiver noise temperature T_r , referred to the antenna terminals. Numbers in Table 30.2 are based on the fundamentals described above and on hypothetical antennas and receivers that conform to good amateur practice in the year 2009; they have been rounded to two significant figures. It is possible to do slightly better than these numbers — for example, by

building antennas with lower sidelobe response or preamplifiers with still lower noise figure — but it's not easy!

The topmost curve in Figure 30.4 illustrates clearly why the frequency range from 100 MHz to 10 GHz is optimum for EME communication. Figure 30.5 shows that further reductions of T_s must come from lower T_r or better suppression of antenna sidelobes. There is nothing you can do about noise from the CMB, atmosphere, moon, or Galaxy entering your main beam! For comparison, the very best professional receiving equipment achieves system noise temperatures around 20 K in the 1–2 GHz region — only a few dB better than current amateur practice. These systems generally use cryogenic receivers and very large dish antennas that can provide better suppression of sidelobes.

Having established reasonable target figures for system noise temperature, we can now proceed to estimate minimum antenna and power requirements for an EME-capable station on each amateur band. Rearrangement of Equations (5) and (6) yields the following relation for transmitter power P_t in dBW:

$$P_t = SNR - G_t - G_r - L + 10 \log(kT_s B). \quad (9)$$

Values for L and T_s can be taken for each amateur band from Tables 30.1 and 30.2. For illustrative purposes let's assume $SNR = 3$ dB and $B = 50$ Hz, values appropriate for a good human operator copying a marginal CW signal. (The 50 Hz effective bandwidth may be established by an actual filter, or more commonly by the operator's "ear-and-brain" filter used together with a broader filter.) For antennas we shall assume bays of 4 long Yagis for the 50 – 432 MHz bands, parabolic dishes of diameter 3 m on 1296 and 2304 MHz, and 2 m dishes on the higher bands. Representative gains and half-power beamwidths for such antennas are listed in columns 3 and 4 of Table 30.3. Column 5 then gives the necessary transmitter power in watts, rounded to two significant figures. A station with these baseline capabilities should be self sufficient in terms of its ability to overcome EME path losses — and thus able to hear its own EME echoes and make CW contacts with other similarly equipped EME stations. Note that the quoted minimum values of transmitter power do not allow for feedline losses; moreover, a CW signal with $SNR = 3$ dB in 50 Hz bandwidth hardly represents "armchair copy". At the highest frequencies, issues of oscillator stability and Doppler spreading might make the assumed 50 Hz bandwidth unrealistically narrow, thus requiring somewhat more power or a larger antenna. On the other hand, lower power and smaller antennas can be sufficient for working stations with greater capabilities than those in the table.

Other factors can reduce the minimum power or antenna gains required for successful EME, at least some of the time. One possibility, especially effective at 50 and 144 MHz at low moon elevations, is to take advantage of reflections from the ground (or better still, water) in front of your antenna. Often referred to as *ground gain*, these reflections can add as much as 6 dB to an antenna's effective gain at elevations where the reflections are in phase with the direct signal. Another possibility is to use more efficient coding and modulation schemes than provided by Morse coded CW.

Coding and Modulation

International Morse code with on-off keying (OOK) is an excellent general purpose communication mode. It is easy to implement and performs well in weak-signal conditions. EME operating procedures for CW usually include multiple repetitions so that essential parts of a bare-minimum QSO can be assembled from fragments copied on signal peaks. However, modern communication theory points the way toward modulation schemes significantly more efficient than OOK, codes better than Morse, and error-control methods more effective than simple repetition. Amateur experiments with these ideas have led to the current popularity of digital EME on the VHF and lower UHF bands. In general, an efficient digital mode designed for basic communication with weak signals will compress user messages into a compact form and then add multi-fold redundancy in the form of a mathematically defined error-correcting code (ECC). Such codes can ensure that full messages are recoverable with high confidence, even when many transmitted symbols have been lost or corrupted.

A number of distinct sources may contribute to the improved performance of such a mode over CW. Multi-tone FSK (M-FSK) is a more efficient modulation than OOK, in part because each received symbol is roughly the equivalent of a full character, rather than a single dot or dash. For equivalent messages, M-FSK can therefore be keyed much more slowly than CW and detected in a much smaller bandwidth. Morse code is self-synchronizing at the character level (if a signal is strong enough for letters to be recognized), but a Morse transmission contains no useful information for synchronizing a whole message. This fact makes it difficult to piece together copied fragments of a CW message being sent repeatedly. In contrast, a synchronized digital transmission with ECC can encode the complete message into a new data format designed to enhance the probability that successful decoding will produce the message's full information content, with everything in its proper place. For the limited purpose of exchanging callsigns, signal reports, and modest amounts of additional information, digital EME contacts can be made

at signal levels some 10 dB below those required for CW, while at the same time improving reliability and maintaining comparable or better rates of information throughput. Depending on your skill as a CW operator, the digital advantage may be even larger. Thus, digital EME contacts are possible between similar stations with about 10 dB less power than specified in Table 30.3, or with 5 dB smaller antenna gains at both transmitter and receiver. An excellent example is the highly portable EME setup of DL3OCH, shown in Figure 30.6. With a single long yagi (59 elements, 5 m boom, 21.8 dBi gain), a 100 W solid state amplifier, and the JT65C digital mode², this equipment has helped to provide dozens of new DXCC credits on 1296 MHz from countries with little or no regular EME activity.

BUILDING AN EME STATION

Antennas

The antenna is arguably the most important element in determining an EME station's capability. It is not accidental that the baseline station requirements outlined in Table 30.3 use Yagi arrays on the VHF bands and parabolic dishes at 1296 MHz and above: one of these two antenna types is almost always the best choice for EME. The gain of a modern, well designed Yagi of length l can be approximated by the equation

$$G = 8.1 \log(l/\lambda) + 11.4 \text{ dBi}, \quad (10)$$

and stacks of Yagis can yield close to 3 dB (minus feedline losses) for each doubling of the number of Yagis in the stack. For comparison, the gain of a parabolic dish of diameter d with a typical feed arrangement yielding 55% efficiency is

$$G = 20 \log(d/\lambda) + 7.3 \text{ dBi}. \quad (11)$$

The gains of some nominal antennas of each type are illustrated graphically in Figure 30.7, which helps to show why Yagis are nearly always the best choice for EME on the VHF bands. They are light, easy to build, and have relatively low wind resistance. Stacks of four Yagis are small enough that they can be mounted on towers for sky coverage free of nearby obstructions. Larger arrays of 8, 16, or even more Yagis are possible, although the complexity and losses in phasing lines and power dividers then become important considerations, especially at higher frequencies. Long Yagis are narrowband antennas, usable on just a single band.

We usually think of the linear polarization of a transmitted signal as being “horizontal” or “vertical”. Of course, on the spherical Earth these concepts have meaning only locally. As seen from the moon, widely separated horizontal antennas may have very different orientations (see Figure 30.8). Therefore, in the absence of Faraday rotation an EME signal transmitted with

horizontal polarization by station A will have its linear polarization misaligned at stations B and C by angles known as the *spatial polarization offset*. In Figure 30.8 the signal from A arrives with vertical polarization at B and at 45° to the horizon at C. Suppose C is trying to work A, and $\theta_s = 45^\circ$ is the spatial polarization offset from A to C. The return signal from C to A will be offset in the opposite direction, that is, by an amount $-\theta_s = -45^\circ$. The Faraday rotation angle θ_F , on the other hand, has the same sign for transmission in both directions. Thus the net polarization shift from A to C is $\theta_F + \theta_s$, while that from C to A is $\theta_F - \theta_s$. If θ_F is close to any of the values $\pm 45^\circ, \pm 135^\circ, \pm 225^\circ, \dots$, then one of the net polarization shifts is nearly 90° while the other is close to 0° . The result for stations with fixed linear polarization will be apparent one-way propagation: for example, A can copy C, but C cannot copy A.

Obviously no two-way contact can be made under these conditions, so the operators must wait for more favorable circumstances or else implement some form of polarization control or polarization diversity. One cost-effective solution is to mount two full sets of Yagi elements at right angles on the same boom. Arrays of such cross-polarized or “Xpol” Yagis make especially attractive EME antennas on the VHF and lower UHF bands because they offer a flexible solution to the linear-polarization misalignment problem. As an example, Figure 30.9 shows the 4×10 element, dual-polarization EME array at KL7UW; this antenna and a 160 W solid-state amplifier have accounted for hundreds of EME contacts on 2 meters.

At 1296 MHz and above, gains of 30 dBi and more can be achieved with parabolic dishes of modest size. As a result, these antennas are almost always the best choice on these bands. Their structure does not depend on any radio frequency resonances, so in many ways dishes are less critical to build than Yagis. Element lengths in high-gain Yagis must be accurate to better than 0.005λ , while the reflecting surface of a dish need be accurate only to about 0.1λ . Mesh surfaces are attractive at frequencies up to at least 5 GHz, because of their light weight and lower wind resistance. Openings in the mesh can be as large as 0.05λ without allowing much ground noise to feed through the surface. A parabolic antenna has a single feed point, so there are no losses in phasing lines or power splitters. You can use a dish on several bands by swapping feeds, and with suitable feed designs you can produce either linear or circular polarization, including dual polarizations. A very attractive and convenient option is to transmit in one sense of circular polarization and receive in the opposite sense. Transmitting in right-hand circular (RHC) and receiving in LHC has become the standard for EME at 1296 and 2304 MHz, and will probably become the standard on higher bands as well.

As made clear in Figure 30.7, the 432 MHz band lies in a transition region where both Yagis and parabolic dishes have attractive features. Either four long Yagis or a 6 m dish can produce enough gain (about 25 dBi) to let you work many other EME stations on this band. Many linear-polarization systems are already in use — for good reason, since most amateur use of this band is for terrestrial communication — so converting everyone to circular polarization is impractical. Therefore, schemes have been devised to physically rotate dish feeds and even whole Yagi arrays to cope with the resulting polarization alignment problems. Another scheme is to use a dual-polarization dish feed or dual-polarization Yagis, as described above and increasingly used on 144 MHz. This approach has not yet gained wide popularity on 432 MHz, however.

A clean pattern with good suppression of side and rear lobes is important for all EME antennas — especially at 432 MHz and above, where excessive noise pickup through sidelobes can significantly increase T_s . For Yagi arrays you should use modern, computer-optimized designs that maximize G/T_s , the ratio of forward gain to system noise temperature. Be sure to pay attention to maintaining a clean pattern when stacking multiple antennas. First sidelobes within 10–15° of the main beam may not be a major problem, because their solid angle is small and they will look mostly at cold sky when EME conditions are favorable. Side and rear lobes farther from the main beam should be suppressed as much as possible, however. Remember that even close-in sidelobes will degrade your receiving performance at low elevations. For parabolic dishes, G/T_s is optimized by using a feed with somewhat larger taper in illumination at the edge of the dish than would yield the highest forward gain. Best forward gain is generally obtained with edge taper around –10 dB, while best G/T_s occurs around –15 dB. Edge taper of –12 dB is usually a good compromise. Some good reproducible designs for dish feeds are described in references at the end of this section³.

Antenna Mounts

EME antennas have high gain and narrow main beams that must be properly aimed at the moon in two coordinates. Although polar mounts (one axis parallel to the Earth's axis) have sometimes been used, by far the most popular mounting scheme today is the elevation-over-azimuth or *Az-El* mount. Readily available computer software (see sidebar) can provide azimuth and elevation coordinates for the moon, and a small computer can also control antenna positioning motors to automate the whole pointing system. For mechanical reasons it is desirable to place the antenna's center of gravity close to the intersection of the vertical (azimuth) and horizontal (elevation) axes. On the other hand, the mounting structure must not

interfere with critical active regions of the antenna. Stacked Yagis are generally mounted so that metallic supporting members are perpendicular to the radiating elements or located at midpoints where the effective apertures of separate Yagis meet. Feedlines and conducting support members must not lie in the active planes containing Yagi elements, unless they run wholly along the boom. For dual-polarization Yagis, feedlines should be routed toward the rear of each Yagi and any mid-boom support members must be non-conducting. For EME there is nothing magical about using horizontal and vertical for the two orthogonal polarizations, and there are some advantages to mounting cross-Yagis with elements in the “×” rather than “+” orientation⁴.

Parabolic dishes are usually mounted from behind, with counterweights extending rearward to relieve torque imbalance on the elevation axis. Screw-jack actuators designed for positioning 1980’s-style TVRO dishes can be readily adapted for elevation control⁵. Standard heavy-duty antenna rotors or prop-pitch motors can be used for azimuth positioning of dishes up to about 3 m in size. Larger dishes may require heavier, one-of-a-kind designs for pointing control. Figures 30.10 – 30.12 show examples of parabolic dishes in the 2 – 3 m range, neatly and successfully outfitted for EME at VA7MM and N4MW.

Feedlines, Preamplifiers, and T/R Switching

Any feedline between the antenna and receiver introduces attenuation and noise, so at UHF and above it is vital that the low-noise preamplifier (LNA) be mounted very close to the antenna terminals. At ambient temperature, every 0.1 dB of loss in front of the LNA adds at least 7 K to the effective T_r , and therefore to T_s . On bands where T_a is much lower than ambient, even 0.1 dB of attenuation can result in 0.5 dB loss of receiver sensitivity. LNA gain should be sufficient to overcome feedline losses and dominate the noise contributed by subsequent stages by at least 15–20 dB. Current practices usually employ one or, especially at 432 MHz and above, two low-noise GaAsFET or HEMT transistors in the preamplifier, with only a simple noise impedance matching circuit between the first active device and the antenna. Only if severe out-of-band interference is present should a narrow filter be placed ahead of the first LNA. Bandpass filtering is often desirable between LNA stages, and may be used without significant impact on system noise temperature. The feedhorn of a dish antenna can have a valuable high-pass effect that attenuates signals at lower frequencies.

The same antenna is generally used for both transmitting and receiving, so the LNA must be out of the line and protected when transmitting. Figure 30.13a illustrates a preferred switching arrangement that uses two separate feedlines: a low-loss line to carry transmitter power, and a

relatively inexpensive feedline from LNA to receiver. A high-power relay K1 at the antenna handles T/R switching; a second relay, K2, may be used to protect the LNA in case the isolation at K1's receive port is inadequate.

Additional relays are required in order to make best use of a dual-linear-polarization system. Figure 30.13b shows an arrangement that lets you select either horizontal or vertical polarization for transmitting (via relay K5) and use both polarizations simultaneously for receiving. A dual-channel receiver can form a linear combination of signals in the two channels to match the polarization of a desired signal exactly, whatever its angle. Such optimization is readily accomplished in a receiver whose last stages are defined and implemented in software, as in the highly effective Linrad⁶ system designed by SM5BSZ. For digital EME using dual-polarization antennas, Linrad and a software program called MAP65 make an especially powerful combination⁷.

With circular polarization you may not need a high-power T/R relay at all. Figure 30.13c shows a typical arrangement with transmitter connected to one port of a feed horn providing both senses of circular polarization, and the LNA to the other port. Since the isolation between ports may be only 20 or 30 dB, a low-power relay protects the LNA during transmit periods. In all of these schemes, suitable sequencing should be used to assure that the LNA is disconnected before transmission can begin. Many amateurs find it best to use the energized position of T/R relays on receive. When the station is not in use, preamplifiers will then be disconnected from the antenna.

Transmitters and Power Amplifiers

Weak signals are best detected in a bandwidth no wider than the signal itself. As a consequence, EME systems must use stable oscillators. For best results with CW your frequency drift over a minute or so should be no more than 10 Hz at the operating frequency; with digital modes the ideal target may be several times smaller. Most modern transceivers are stable enough at VHF, but some only marginally so at UHF. The crystal oscillators used in transverters may need temperature compensation for adequate stability; better still, they can be phase-locked to an external high-stability reference oscillator. A number of digital EME QSOs have been made on the 23 cm and 13 cm bands using only 5 – 10 W transmitter power and parabolic dishes in the 2 – 3 m range — much smaller systems than the baseline examples listed in Table 30.3 — but such contacts generally depend on having stabilized local oscillators. Especially for digital

EME, where detection bandwidths <10 Hz are used, unstable oscillators lead directly to loss of sensitivity.

After frequency stability, the most important specification for an EME transmitter is power output. The maximum power practically achievable by amateurs ranges from 1500 W on the VHF and lower UHF bands down to the 100 W range at 10 GHz. Fortunately, the required power levels for EME (Table 30.3) also decline with frequency. At 432 MHz and below, triode or tetrode vacuum tubes with external-anode construction can provide ample gain and power output. Some popular tubes include the 4CX250, 8930, 8874, 3CX800, 8877, GU-74B, GS-23B, and GS-35B. Amplifiers using one or a pair of these (or other similar tubes) can provide output powers ranging up to 1000 or 1500 W on the 50 – 432 MHz bands. VHF and UHF power amplifiers based on solid state power devices have also become viable alternatives. Many amateurs have built amplifiers using these techniques, and commercial designs are available.

At frequencies above 1 GHz, transit-time limitations and physical structures prevent most high-power vacuum tubes from performing well. For many years planar triodes in the 2C39/7289/3CX100 family have been the mainstays of amateur 1296 MHz power amplifiers. Some higher power tubes for this band include the GI-7B, GS-15, TH347, TH308, and YL1050. The 2C39/7289/3CX100 tubes, as well as the GI-7B and GS-15, generally require water cooling at the power levels desirable for EME. Solid-state power amplifiers are also available for the microwave bands; as prices come down and power levels increase, these units are becoming more popular with EME operators. Surplus solid-state amplifiers usable on the 902, 2304, and 3456 MHz bands have been attractive buys over the last few years, providing output power up to several hundred watts at reasonable cost. Two, four, or even more units are sometimes used together to achieve higher output. At the highest EME frequencies surplus travelling wave tube (TWT) amplifiers can provide power levels up to several hundred watts.

One final point must be made in a discussion of high power amplifiers. Anyone who has thought about how a microwave oven works should know why RF safety is an important issue. Dangerous levels of radio frequency radiation exist inside and at short distances from power amplifiers and antennas. In normal operation, power density is highest in the immediate vicinity of small, low-gain antennas such as feeds for parabolic dishes. EME operators should be aware that ERP (effective radiated power) can be highly misleading as a guide to RF hazards. Somewhat counter-intuitively, a large, high-gain antenna helps to reduce local RF hazards by distributing RF power over a large physical area, thus reducing power density. Be sure to read Chapter 3 and pay attention to the RF protection guidelines there.

GETTING STARTED

Perhaps you already have a weak-signal VHF or UHF station with somewhat lesser capabilities than those recommended in Tables 30.2 and 30.3, and would like to make a few EME contacts before possibly undertaking the task of assembling a “real” EME station. On 144 and 432 MHz — probably the easiest EME bands on which to get started — you can visually point your single long Yagi at the rising or setting moon and work some of the larger EME stations. Your daily newspaper probably lists the approximate times of moon rise and moon set in your vicinity; many simple web-based calculators can give you that information as well as the moon’s azimuth and elevation at any particular time (see sidebar). These aids may be all you need to make your first EME contacts, especially if you take advantage of the weak-signal capabilities of an efficient digital mode. To optimize your chances of success, adapt your operating procedures to the prevailing standards that other EME will be using, as discussed below. For your first attempts you may want to make pre-arranged schedules with some established stations.

Tracking the Moon

For serious EME work you’ll want a more general way of keeping your antenna pointed at the moon. The Earth and moon complete their mutual orbit every 27.3 days, one sidereal month. The lunar orbit is inclined to the plane of the ecliptic, the Earth-Sun orbital plane, by 5.1° . Since the Earth’s equator is itself inclined at 23.5° to the ecliptic, the moon’s path through the sky swings north and south of the equator by as much as 28° in a monthly cycle (see Figure 30.3). Predicting the moon’s exact position is a complicated problem in celestial mechanics, but is readily handled to sufficient accuracy by simple computer software. In general the problem can be reduced to (1) calculating the moon’s position on the sky, as seen by a hypothetical observer at the center of the Earth; (2) applying a parallax correction to yield the lunar position at a specified location on the Earth’s surface; and (3) converting the astronomical coordinates of right ascension and declination to azimuth and elevation at the specified terrestrial location. Of course, the Earth’s rotation and moon’s orbital motion imply that the moon’s position is constantly changing. Suitable computer software can follow these changes and generate the necessary commands to keep your antenna pointed at the moon. Several free or inexpensive software packages with moon-tracking features are listed in the sidebar, and such facilities are built into the programs WSJT and MAP65 widely used for digital EME. For good results you should aim for pointing accuracies of about $1/4$ of your half-power beamwidth, or better.

System Evaluation

Careful measurements of your EME system's performance can help to determine where station improvements can be made. Transmitter performance is essentially determined by power output, feedline losses, and antenna gain. The first two can be measured in standard ways, but antenna gain is much more difficult. The most useful figure of merit for receiving performance is G/T_s , and while absolute measurements of either G or T_s separately are difficult, you can measure their ratio with useful accuracy and compare it with expectations. One technique particularly useful at 432 MHz and above is to use the sun as a broadband noise source. Point your antenna at cold sky and then at the sun, and measure Y , the ratio of received noise power in the two directions. Operate your receiver at maximum bandwidth with the AGC off, and if possible make the observations with the sun at elevation 30° or higher.

To calculate G/T_s from Y , you will need a contemporaneous estimate of solar flux density at your operating frequency. Daily measurements of solar flux are obtained at a number of standard frequencies and made available online (see sidebar); you can interpolate an approximate flux value for the amateur band in question. Solar flux densities vary with sunspot activity, and day-to-day or even hour-to-hour variations are especially large at lower frequencies and near solar maximum. Representative monthly median values for six frequencies are presented in Figure 30.14 over sunspot cycle 23. As a starting point, you can estimate a value of solar flux for your band and a similar point in the sunspot cycle directly from Figure 30.14. Then, if S^* is the solar flux density in units of $\text{W m}^{-2} \text{Hz}^{-1}$ and Y is expressed as a dimensionless ratio, the corresponding value of G/T_s in dB is given by

$$\frac{G}{T_s} = 10 \log \left(\frac{8\pi k (Y-1)}{S^* \lambda^2} \right). \quad (12)$$

Solar fluxes are usually quoted in Solar Flux Units ($1 \text{ SFU} = 10^{-22} \text{ W m}^{-2} \text{Hz}^{-1}$), and with S in those units Equation (12) can be reduced to the simpler relation

$$\frac{G}{T_s} = 10 \log \left(\frac{3.47 (Y-1)}{S \lambda^2} \right). \quad (13)$$

Representative values of G/T_s and Y for the example antennas of Table 30.3 are given in columns 4 and 5 of Table 30.4. The Y values are based on quiet-sun flux densities typical of years near sunspot minimum.

Of course, receiving your own echoes from the moon provides the best guarantee that your equipment is capable of EME communication with comparable stations. Transmitting a few

dashes, then standing by to hear your lunar echo some 2.5 s later, brings a thrill that most hams never forget. With suitable signal-processing software, echoes can be detected and measured even with relatively low-power equipment. Version 4.9.8 of the WSJT program (see sidebar) includes an automated echo-testing facility that is useful for quantitative measurements even if your echoes are many dB below the audible threshold.

Operating Procedures

The more that's known about likely structure, content, and timing of a transmitted message, the easier it is to copy. EME signals are often near the threshold of readability, so it is highly desirable to standardize operating procedures and message structure, and to provide transmissions with enough redundancy to bridge likely gaps in reception. You may wish to make your first EME QSOs with the aid of explicit schedules: that is, arrangements to attempt a contact with a particular station at a specified time and frequency. EME schedules usually state the duration of timed transmissions as well as starting time, transmitter frequency, and an indication of which station will transmit first. For a minimal QSO, message information is often reduced to the bare essentials of call signs, signal reports, and acknowledgments. The signal report is sometimes reduced to a "yes or no" indication of whether both call signs have been successfully copied. Remember to allow for Doppler shifts, especially at higher frequencies where the offset may exceed your received bandwidth. Most moon-tracking software used for EME can display the expected frequency shift for your own echoes as well as that for a distant station. In a scheduled QSO attempt, keep your transceiver set to the schedule frequency and use its RIT knob to search for the other station around his expected Doppler shift. When looking for contacts at random, especially at 432 MHz and above, set your RIT to the expected Doppler shift of your own echoes. If a station you copy does likewise, you will find each other's signals on the same frequency as your own echoes.

Morse Coded CW

By convention, a minimal CW EME contact usually follows a format something like the sequence of messages in Table 30.5. If timed T/R sequences are being used, the essential information is repeated for the full duration of a sequence. The standard QSO procedures involve a number of different messages sent in sequence, and operators do not proceed to the next message until they have copied the essential information (call signs, signal report, acknowledgements) in previous messages. After callsigns have been copied, a signal report is sent. Because CW "dahs" are easier to discern than "dits", a default EME signal report

(essentially meaning “I have copied both call signs”) is the letter “O”. A station receiving callsigns and “O” responds with “RO”, and a final acknowledgment of a valid contact is signified by sending “RRR ...”. On 432 MHz and above, the letter “M” is sometimes used as an alternative signal report meaning “both call signs copied with difficulty.” Of course, when signals are adequate for reasonably good copy normal RST signal reports can be used and other restrictions on message structure and timing relaxed. In non-scheduled operation, it frequently happens (for example, in response to your CQ) that you can recognize and copy your own call more easily than the other station’s call. The sequence “YYY...” (for “Your call”) can be sent to ask a calling station to send his call only, repeating it many times. A contact is considered complete and valid when “RRR” has been received, *i.e.*, after message number 5 in Table 30.5 has been received. However, at this point the other station does not know that his acknowledgment was received — so it is normal to finish with something like message 6.

The conventional duration of transmit and receive periods is different on different bands and has evolved somewhat over time. On 50 and 144 MHz, stations usually transmit for one full minute and then receive for a full minute. On 432 MHz and above, schedules with 2.5-minute transmissions have been standard. The longer period gives stations with mechanically variable polarization adequate time to peak a received signal. CW sending speed is generally around 12 to 15 wpm. Some operators find it helpful to use greater-than-normal spacing between complete letters. Keep in mind that characters sent too slowly may be chopped up by typical EME fading, while code sent too fast will be jumbled. When transmitting call sequences, send the other station’s call once, followed by “DE” and your own call once or twice. Then pause and repeat the sequence. This cadence sets a rhythm so that the receiving operator can anticipate when the missing parts of a message can be expected to arrive. Send with proper spacing; the use of a programmable keyer is especially helpful and encouraged. A signal buried in the noise and accompanied by fading is hard enough to copy, without the added complication of irregular sending.

Digital EME with JT65

Most digital EME is presently done with the JT65 protocol,² as implemented in the computer programs WSJT and MAP65 (see sidebar). Like other popular digital modes, this one requires a personal computer with a sound card for audio input and output. JT65 uses structured message formats, a Reed Solomon error-correcting code with slightly more than five-fold redundancy, and one-minute T/R sequences. Signal peaks and dropouts due to multipath fading do not affect

individual characters or words, but rather the probability of decoding the whole message. The modulation is 65-tone frequency shift keying (65-FSK) with computer-generated audio tones modulating a single-sideband transmitter in USB mode. As expected from the theory described briefly above, results show that JT65 contacts can be made at signal levels about 10 dB less than those needed for CW. The detection bandwidth implemented in the receiving software for JT65 sub-modes A, B, and C is 2.7, 5.4, and 10.8 Hz, respectively. These may be compared with minimum bandwidths of 25–50 Hz for 15 WPM CW. Requirements on oscillator stability are therefore somewhat more stringent for JT65 than for CW.

Basic procedures for minimal JT65 contacts are very similar to those for CW, and a typical message sequence is shown in Table 30.6. Standard messages include space reserved for Maidenhead grid locators, so this information is normally exchanged along with callsigns. Following CW practice, you should proceed to the next message in the QSO sequence only when information from the previous step has been copied. A default signal report may be sent as “OOO”, but many operators prefer to send and receive numerical signal reports (giving the signal strength in dB, relative to noise power in a standard 2500 Hz bandwidth) as measured by the receiving software. Messages using such reports are shown in the final column of Table 30.6. Many additional details on the usage of JT65 can be found in documentation distributed with the WSJT program. Figure 30.15 shows an example screen shot of K1JT finishing a contact with RU1AA via 144 MHz EME.

Keep in mind that digital EME techniques have been used for less than a decade and are likely to be still evolving. New protocols may be designed in the future using different types of ECC, different message structures, longer or shorter T/R sequences, larger or smaller bandwidths, and so on. The latest information will likely be found online — for example, at some of the internet addresses listed in the sidebar.

Finding QSO Partners

At the time of this writing (early 2009) levels of EME activity are highest on 144 MHz. Almost any time the moon is above your horizon (excluding a few days each month when it is near the plane of the Milky Way), you can find JT65 EME signals in the frequency range 144.100 to 144.160 MHz — often dozens of them, especially on weekends. Hundreds of operators, worldwide, are “on the moon” regularly using JT65 on 144 MHz, and some of the larger stations have made EME contacts with more than two thousand others. Regulations in Japan forbid use of FSK modes above 144.100, so JA callsigns are usually found between

144.070 and 144.100. Operating frequencies of particular stations are often posted on real-time loggers (see sidebar). Explicit schedules can also be made on the loggers, and this is a good way to initiate your first EME contacts. Don't compromise a true EME contact by resorting to the logger after a QSO attempt has been started, however.

CW activity on the 144 MHz band, as well as most EME activity on higher bands in any mode, tends to be concentrated in activity weekends scheduled once each month when the moon is in a favorable location. After 144 MHz, the bands with most EME activity are 1296 and 432 MHz. On those bands random CW (and occasionally SSB) activity is mostly found between .005 and .030 MHz above the lower band edge (for example, between 1296.005 and 1296.030), and digital activity is between .060 and .090, concentrating around .065 or .070. A hundred or more stations are typically active on these bands during the annual ARRL International EME Competition and in other major operating events. The higher microwave bands, especially 2.3 and 3.4 GHz, have at least several dozen regularly active stations. On these and higher bands activity tends to concentrate around .100. Keep in mind that different band segments may be assigned in different parts of the world⁸; for example, North American stations use 2304.100, but some Europeans work around 2320.100. EME activity on the 50, 222, and 902 MHz bands is mostly done with explicit pre-arrangements. The sidebar lists some resources that can help you to find schedule partners and the dates of EME contests and activity weekends.

TABLES

Table 30.1
Two-Way EME Path Loss
with Isotropic Antennas

Frequency (MHz)	Average Path Loss (dB)
50	-242.9
144	-252.1
222	-255.8
432	-261.6
902	-268.0
1296	-271.2
2304	-276.2
3456	-279.7
5760	-284.1
10368	-289.2
24048	-293.5

Table 30.2
Typical Contributions to System Noise Temperature

Frequency (MHz)	CMB (K)	Atm (K)	Moon (K)	Gal (K)	Side (K)	T _a (K)	T _r (K)	T _s (K)
50	3	0	0	2400	1100	3300	50	3500
144	3	0	0	160	100	260	50	310
222	3	0	0	50	50	100	50	150
432	3	0	0	9	33	45	40	85
902	3	0	1	1	30	35	35	70
1296	3	0	2	0	30	35	35	70
2304	3	0	4	0	30	37	40	77
3456	3	1	5	0	30	40	50	90
5760	3	3	13	0	30	50	60	110
10368	3	10	42	0	30	85	75	160
24048	3	70	170	0	36	260	100	360

Table 30.3
Typical Antenna and Power Requirements
for CW EME

Frequency (MHz)	Ant Type ¹	G (dBi)	HPBW (deg)	TxPwr (W)
50	4×12 m	19.7	18.8	1200
144	4×6 m	21.0	15.4	500
432	4×6 m	25.0	10.5	250
1296	3 m	29.5	5.5	160
2304	3 m	34.5	3.1	60
3456	2 m	34.8	3.0	120
5760	2 m	39.2	1.8	60
10368	2 m	44.3	1.0	25

¹Example antennas for 50, 144, and 432 MHz are Yagi arrays with stated lengths; those for 1296 MHz and higher are parabolic dishes of specified diameter.

Table 30.4
Representative G/T_s and Y_{sun}
for Example Antennas

Frequency (MHz)	Ant Type ¹	G (dBi)	G/T_s (dB)	Y_{sun} (dB)
144	4×6 m	21.0	-3.8	4
432	4×6 m	25.0	5.8	12
1296	3 m	29.5	11.1	11
2304	3 m	34.5	15.6	11
3456	2 m	34.8	15.3	9
5760	2 m	39.2	18.8	9
10368	2 m	44.3	22.4	11

Table 30.5
Typical Messages in a Minimal EME CW Contact

Period

1	CQ CQ CQ DE W6XYZ W6XYZ ...
2	W6XYZ DE K1ABC K1ABC ...
3	K1ABC DE W6XYZ OOO OOO ...
4	W6XYZ DE K1ABC RO RO RO ...
5	K1ABC DE W6XYZ RRR RRR ...
6	W6XYZ DE K1ABC TNX 73 ...

Table 30.6
Typical Messages in a JT65 EME Contact

<i>Period</i>	<i>Using shorthand messages</i>	<i>Using long-form messages</i>
1	CQ W6XYZ CN87	CQ W6XYZ CN87
2	W6XYZ K1ABC FN42	W6XYZ K1ABC FN42
3	K1ABC W6XYZ CN87 OOO	K1ABC W6XYZ CN87 -21
4	RO	W6XYZ K1ABC FN42 R-19
5	RRR	K1ABC W6XYZ CN87 RRR
6	73	TNX RAY 73 GL

Notes and References

1. The only exception is the amateur band at 70 MHz, which is assigned in only a few countries and has a low power limit.
2. J. Taylor, K1JT, "The JT65 Communications Protocol", *QEX*, September-October 2005, p 3.
3. M. Franco, N2UO, "Computer Optimized Dual Mode Circularly Polarized Feedhorn", in Microwave Update 2008, ARRL, 2008, and ok1dfc.com/EME/technic/septum/N2UO%20opt.pdf; P. Wade, W1GHZ, "VE4MA and Chaparral feeds with Septum Polarizers", www.w1ghz.org/antbook/conf/VE4MA_Chaparral_septum_feeds.pdf; G. Kollner, DL4MEA, "Designing a Super-VE4MA feed horn for 23 cm and 13 cm," *Dubus*, 1/2007, p 33.
4. L. Åsbrink, SM5BSZ, "The '+' Configuration vs. the 'X' Configuration", www.sm5bsz.com/polarity/simplesw.htm.
5. D. Halliday, KD5RO (now K2DH), "Microwave EME Using a Ten-Foot TVRO Antenna", The ARRL UHF/Microwave Projects Manual, Volume 1, 1996; M. Mattila, VE7CMK, and T. Haynes, VE7CNF, "Project Moonbounce: Earth-Moon-Earth Station VA7MM", www3.telus.net/public/va7mm/eme/.
6. L. Åsbrink, SM5BSZ, "Linrad: New Possibilities for the Communications Experimenter, Parts 1-4", *QEX*, Nov 2002 p 37, Jan 2003 p 41, May 2003 p 36, Sept 2003 p 29; "Linrad with High Performance Hardware", *QEX* Jan 2004, p20; "Linrad Home Page", www.sm5bsz.com/linuxdsp/linrad.htm.
7. J. Taylor, K1JT, "MAP65: A Panoramic, Polarization-Matching Receiver for JT65", in Microwave Update 2007, ARRL, 2007, and physics.princeton.edu/pulsar/K1JT/MAP65.pdf.
8. Y. Mataka, JA4BLC, "Full Spectrum Receiver for 13cm EME". *DUBUS* 3/2005, p 21.

Sidebar: Amateur EME Milestones

- 1953 W3GKP and W4AO detect lunar echoes on 144 MHz
- 1960 First amateur 2-way EME contact: W6HB works W1FZJ, 1296 MHz
- 1964 W6DNG works OH1NL, 144 MHz
- 1964 KH6UK works W1BU, 432 MHz
- 1970 WB6NMT works W7CNK, 222 MHz
- 1970 W4HHK works W3GKP, 2.3GHz
- 1972 W5WAX and K5WVX work WA5HMK and W5SXD, 50 MHz
- 1987 W7CNK and KA5JPD work WA5TNY and KD5RO, 3.4 GHz
- 1987 W7CNK and KA5JPD work WA5TNY and KD5RO, 5.7 GHz
- 1988 K5JL works WA5ETV, 902 MHz
- 1988 WA5VJB and KF5N work WA7CJO and KY7B, 10 GHz
- 2001 W5LUA works VE4MA, 24 GHz
- 2005 AD6FP, W5LUA, and VE4MA work RW3BP, 47 GHz
- 2005 RU1AA works SM2CEW, 28 MHz

Sidebar: Computer and Internet Resources for EME

Software for finding and tracking the moon:

1. MoonSked, by GM4JJJ, www.gm4jji.co.uk/MoonSked/moonsked.htm
2. EME System, by F1EHN, www.f1ehn.org/
3. EME2008, by VK3UM, www.ve1alq.com/vk3um/index.html
4. SkyMoon, by W5UN, www.w5un.net/
5. GJTracker, by W7GJ, www.bigskyspaces.com/w7gj/
6. WSJT, by K1JT, physics.princeton.edu/pulsar/K1JT/
7. Web calculator: www.satellite-calculations.com/Satellite/suncalc.htm

Software for EME performance calculations:

1. EMECalc, by VK3UM, www.ve1alq.com/vk3um/index.html

Digital EME:

1. K1JT: physics.princeton.edu/pulsar/K1JT/

Topical email reflectors:

1. Moon-Net: www.nlsa.com/nets/moon-net-help.html
2. Moon: www.moonbounce.info/mailman/listinfo/moon

Beginner information:

1. W5UN: www.w5un.net/
2. EA6VQ: www.vhfdx.net/jt65bintro.html
3. W7GJ (EME on 50 MHz): www.bigskyspaces.com/w7gj/

Technical references:

1. SM5BSZ: www.sm5bsz.com/linuxdsp/linrad.htm
2. W1GHZ: www.w1ghz.org/antbook/contents.htm
3. GM3SEK: www.ifwtech.co.uk/g3sek/eme/pol1.htm
www.ifwtech.co.uk/g3sek/stacking/stacking2.htm
4. F5VHX: www.rfham.com/g8mbi/g8mbi/pol1.htm
5. Dubus: www.marsport.org.uk/dubus/eme.htm

Chatrooms and Loggers:

1. N0UK: www.chris.org/cgi-bin/jt65emeA
2. ON4KST: www.on4kst.com/chat/
3. HB9Q: hb9q.ch/joomla/

Monthly Newsletters:

1. 144 MHz, by DF2ZC: www.df2zc.de/newsletter/index.html
2. 432 and Above, by K2UYH: www.nitehawk.com/rasmit/em70cm.html

Solar Flux data:

1. Archival: www.ngdc.noaa.gov/stp/SOLAR/ftpsolarradio.html#noonflux
2. Current: www.ips.gov.au/Solar/3/4/2

FIGURE CAPTIONS

Fig 30.1 — Schematic representation of major system components for a (one-way) EME path.

Fig 30.2 — Attenuation caused by misalignment of a linearly polarized signal with the polarization angle of a receiving antenna. The attenuation increases rapidly for alignment errors greater than 45°.

Fig 30.3 — *Top:* All-sky map of sky background temperature at 144 MHz. The dashed curve indicates the plane of our Galaxy, the Milky Way; the solid sinusoidal curve is the plane of the ecliptic. The Sun follows a path along the ecliptic in one year; the moon moves approximately along the ecliptic ($\pm 5^\circ$) each month. Map contours are at noise temperatures 200, 500, 1000, 2000, and 5000 K. *Bottom:* One-dimensional plot of sky background temperature at 144 MHz along the ecliptic, smoothed to an effective beamwidth 15°.

Fig 30.4 — Typical contributions to system noise temperature T_s as function of frequency. See text for definitions and descriptions of the various sources of noise.

Fig 30.5 — Percentage contributions to system noise temperature as a function of frequency.

Fig 30.6 — TF/DL3OCH used a rural road sign to help him give contacts with Iceland to a number of EME operators on 1296 MHz. Bodo has activated many DXCC entities on 1296 MHz EME by using JT65, a single long Yagi, and a 100 W solid state amplifier.

Fig 30.7 — Representative gains of practical Yagi antennas, arrays of Yagis, and parabolic dishes as a function of frequency. Yagi arrays make the most cost-effective and convenient antennas for EME on the VHF bands, while parabolic dishes are generally the best choice above 1 GHz.

Fig 30.8 — The spherical Earth creates spatial polarization offsets for well-separated stations with horizon-oriented linear polarization. Here, a signal transmitted horizontally at A arrived with vertical polarization at B and midway between horizontal and vertical at C. When combined with Faraday rotation, offsets close to 45° can lead to apparent one-way propagation. See text for details.

Fig 30.9 — Array of four 10-element, dual-polarization Yagis at KL7UW. Alaskan frost makes the horizontal and vertical elements stand out clearly. A pair of loop Yagis for 1296 MHz can be seen inside the 2-meter array.

Fig 30.10 — This 3 m TVRO dish with aluminum frame and mesh surface was outfitted for 1296 MHz EME as a joint effort by VA7MM and VE7CNF. The dual-circular polarization feed is a VE4MA/W2IMU design.

Fig 30.11 — Mounting arrangement, counter-weights, and Az/EI control system for the VA7MM 3 m dish.

Fig 30.12 — N4MW outfitted this 2.6 m offset parabolic dish for 10 GHz EME. Equipment mounted at the focus (close-up at bottom) includes LNA, transverter, TWT power amplifier, and feed horn for 10 GHz.

Fig 30.13 — Recommended “front ends” for EME systems include low-noise preamplifiers (LNAs) mounted at the antenna and use separate feedlines for transmitting and receiving. Relay K2 shown in (a) may be omitted if K1 provides adequate isolation of the LNA while transmitting. An arrangement like that in (b) is recommended for a dual-polarization antenna such as an array of cross-Yagis. Transmitter power is sent to one polarization or the other, but received signals in both polarizations are amplified and sent on to a dual-channel receiver. Part (c) shows a suitable arrangement for circular polarization implemented with a two-port, dual-circular-polarization feed horn. In this case, no high-power T/R relay is required.

Fig 30.14 — Monthly median values of solar flux density at six frequencies, over the 11 years of solar cycle 23. Original data are from the Sagamore Hill Observatory in Massachusetts. At the lower frequencies, and especially near solar maximum, day-to-day and even hour-to-hour upward variations can be an order of magnitude larger than those in the monthly medians.

Fig 30.15 — Screen shot of computer program WSJT. K1JT has just finished working RU1AA in JT65B mode, on 144 MHz EME.

Fig 30.1

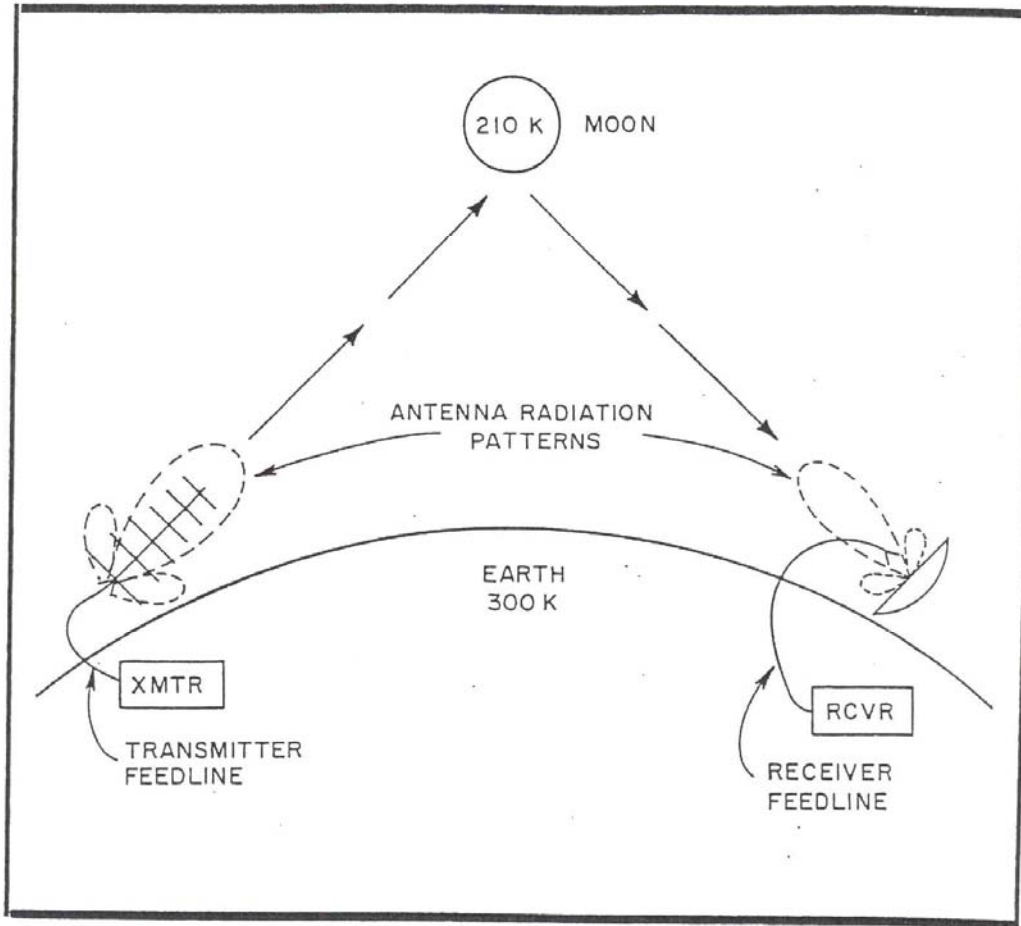

Figure 30.1

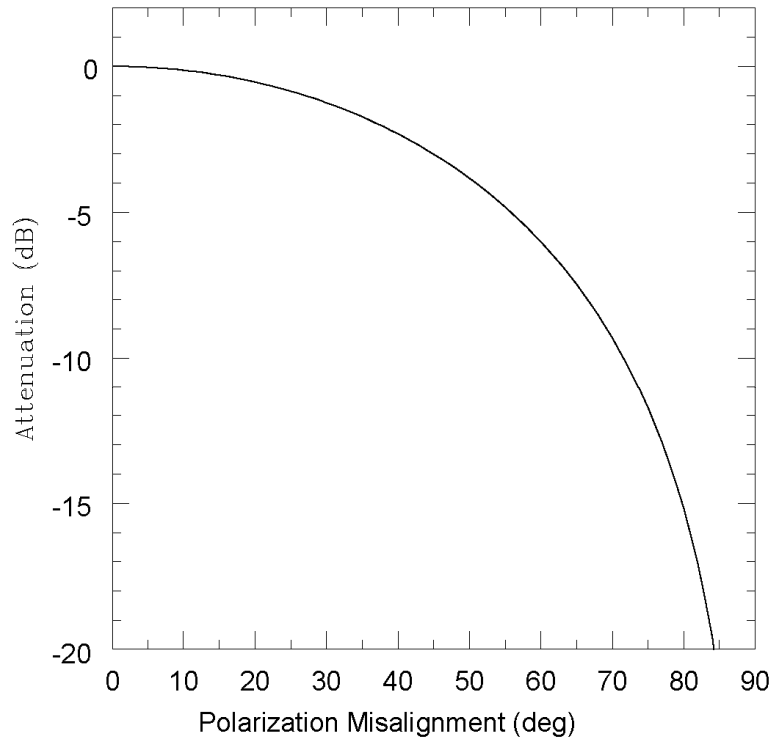

Figure 30.2

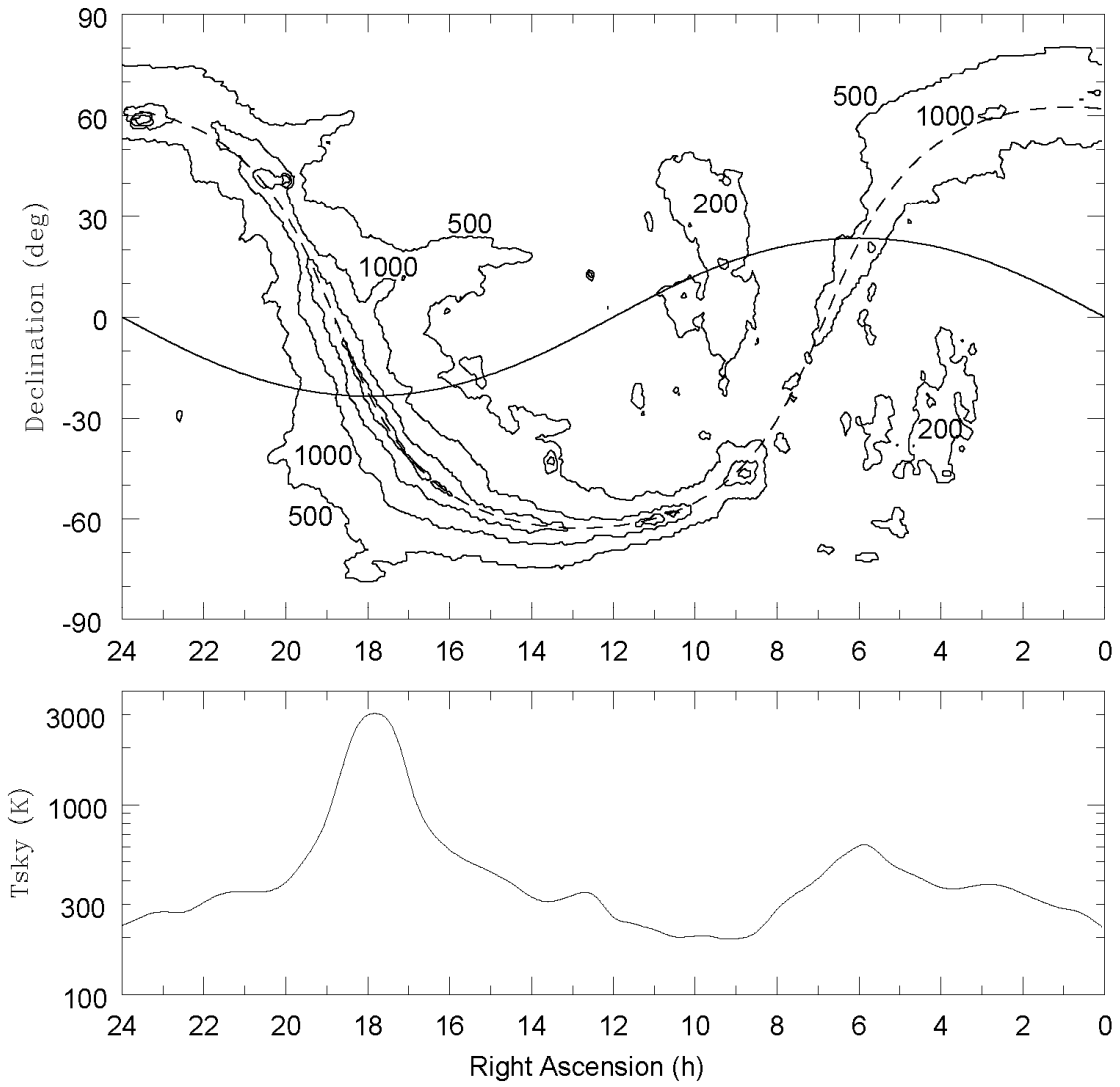

Figure 30.3

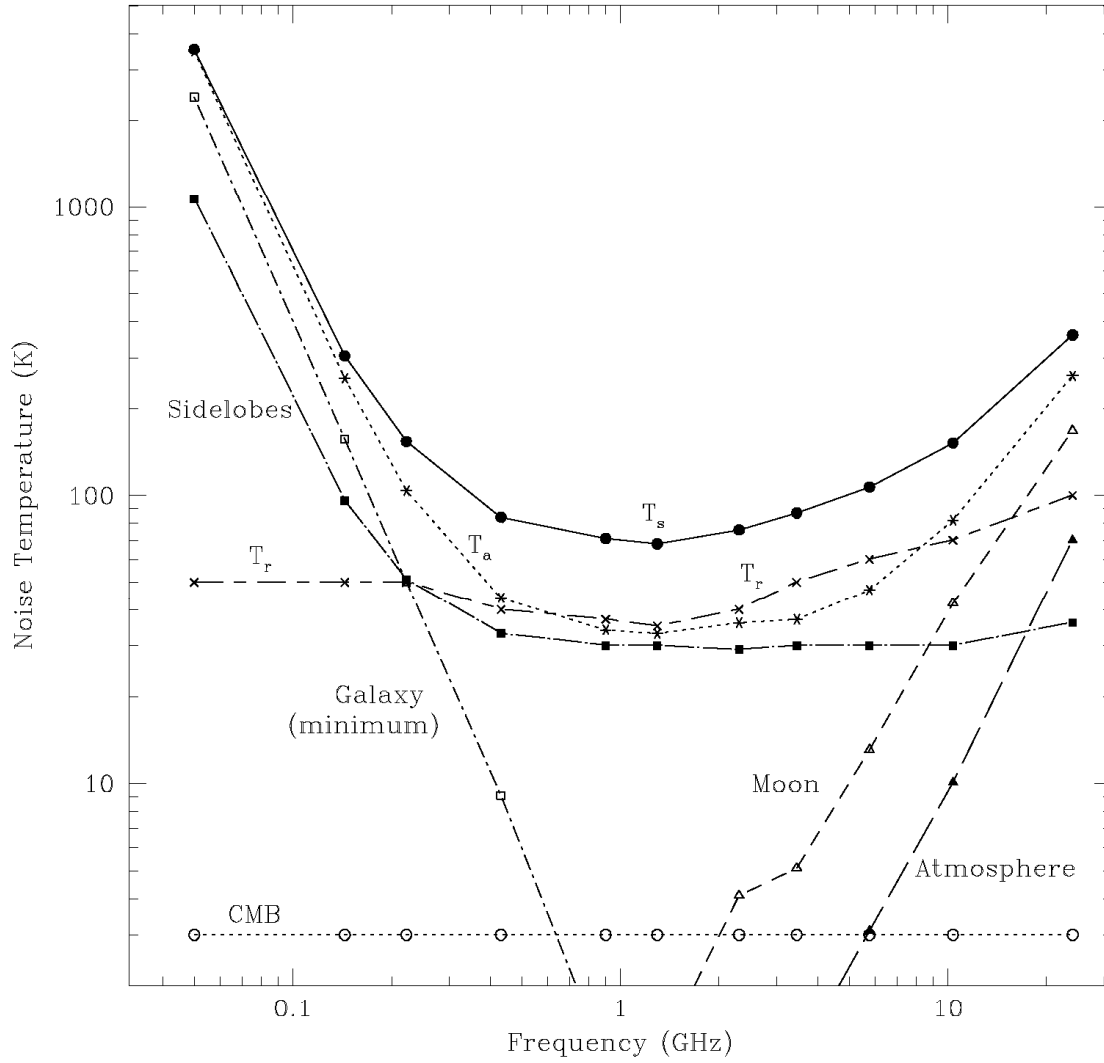

Figure 30.4

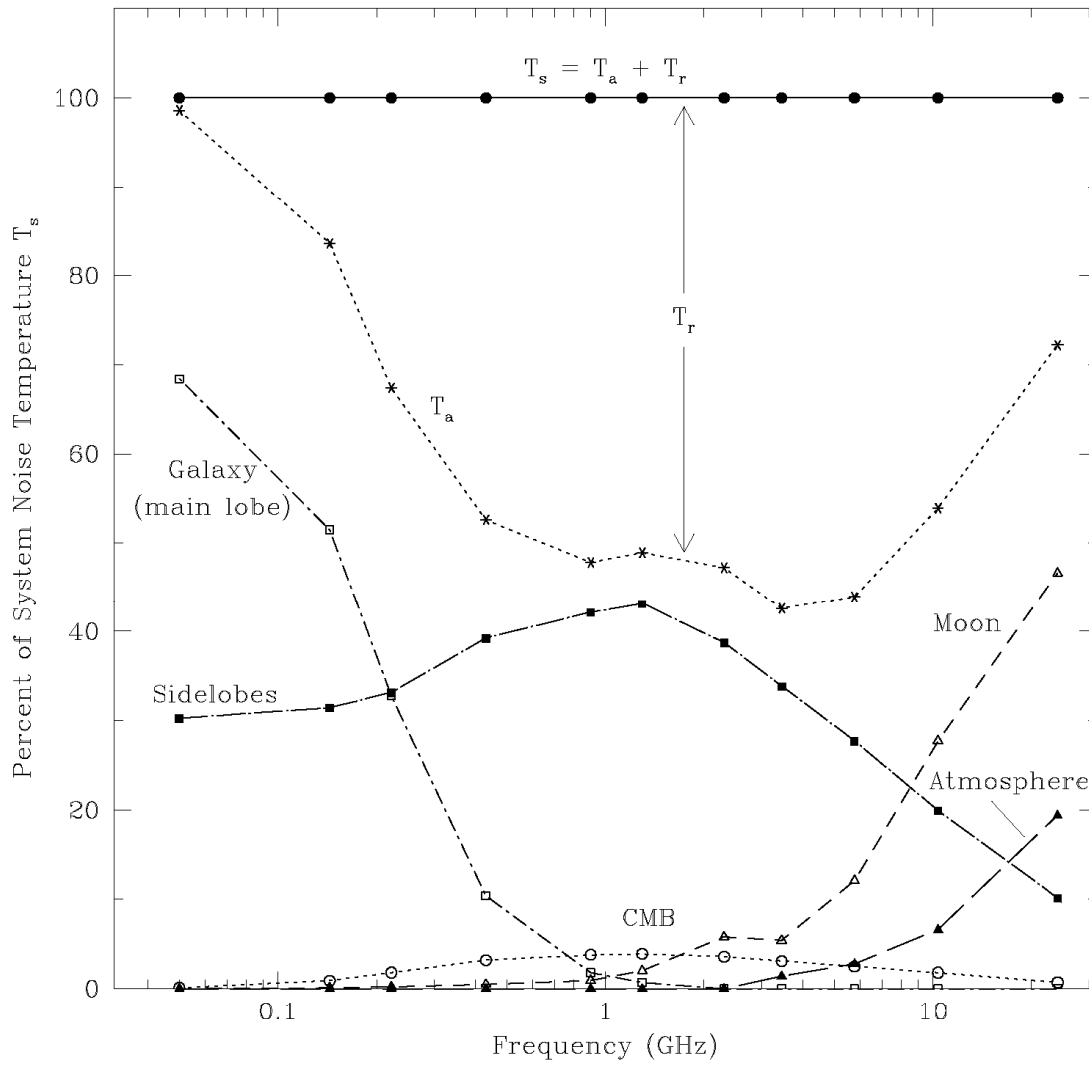

Figure 30.5



Figure 30.6

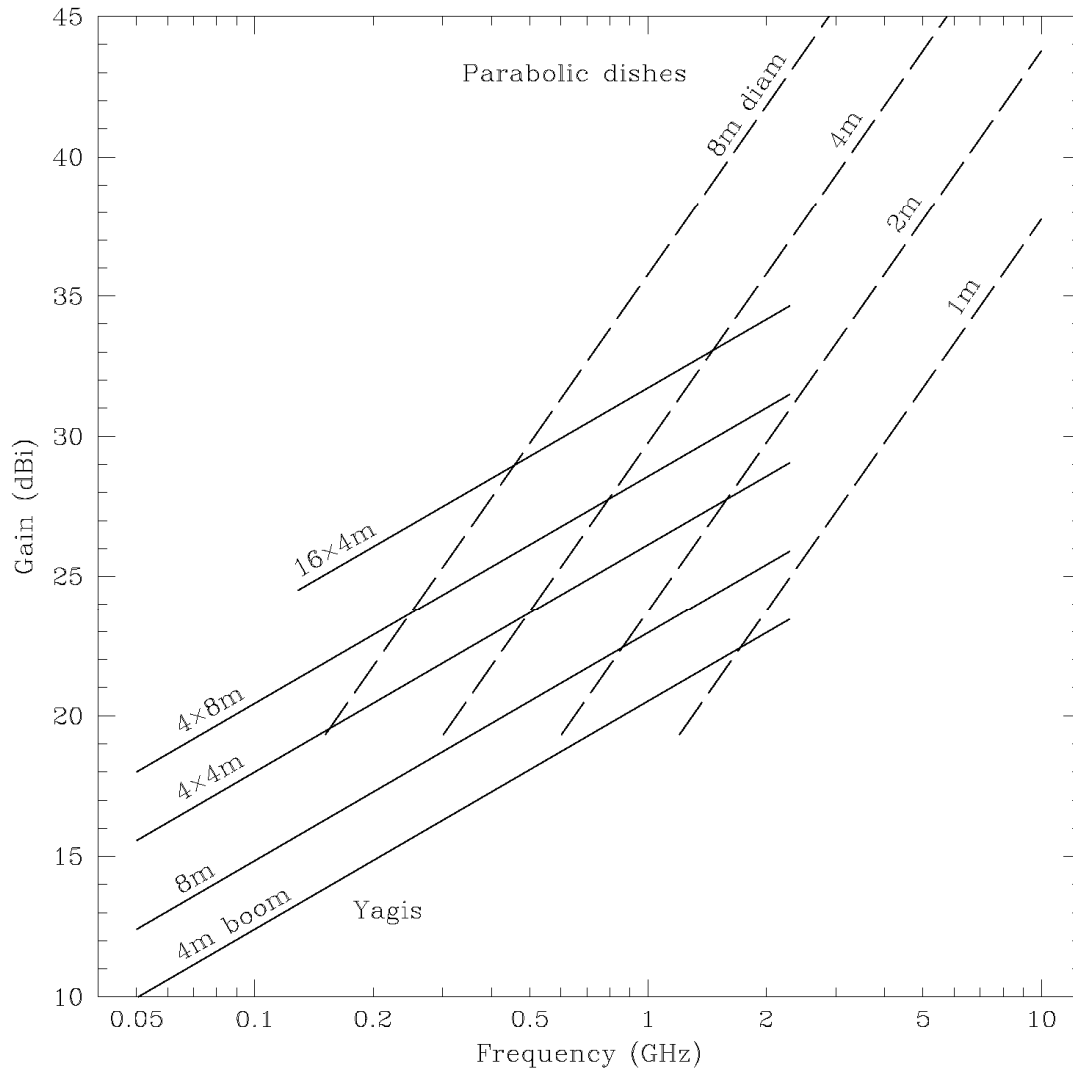

Figure 30.7

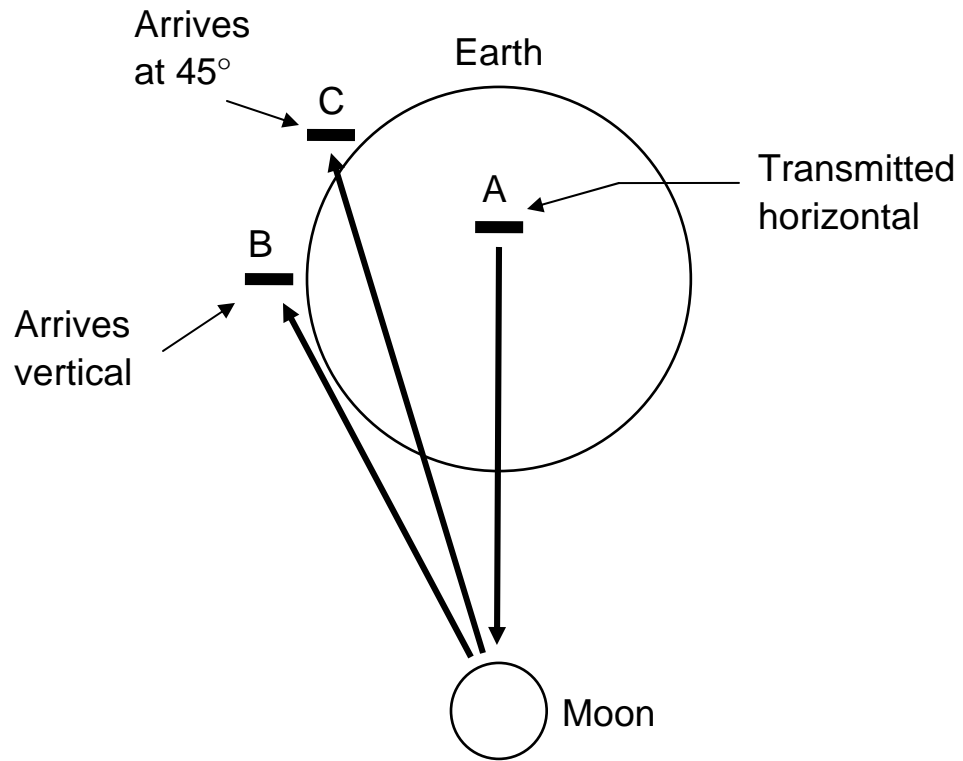

Figure 30.8

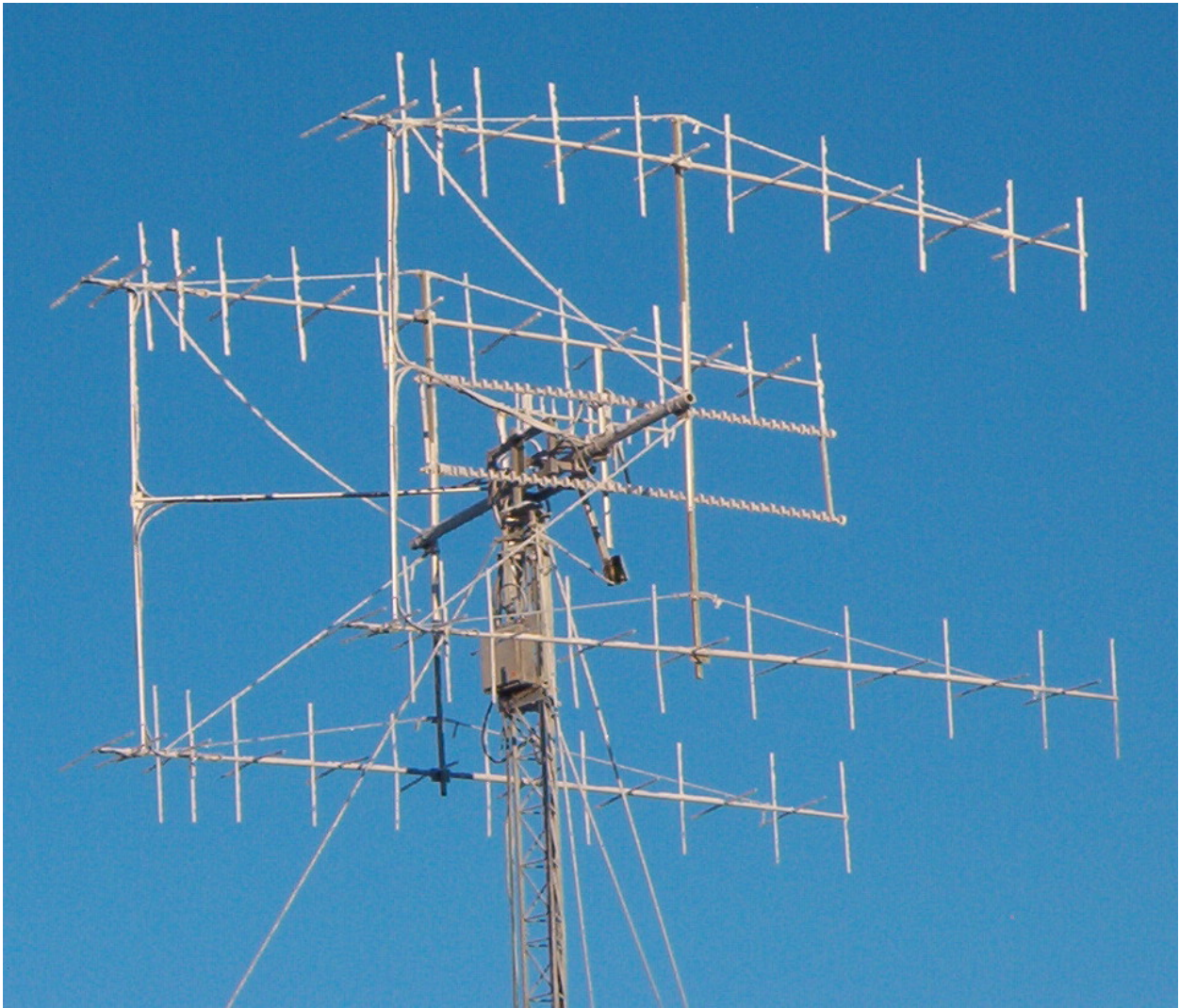

Figure 30.9



Figure 30.10



Figure 30.11

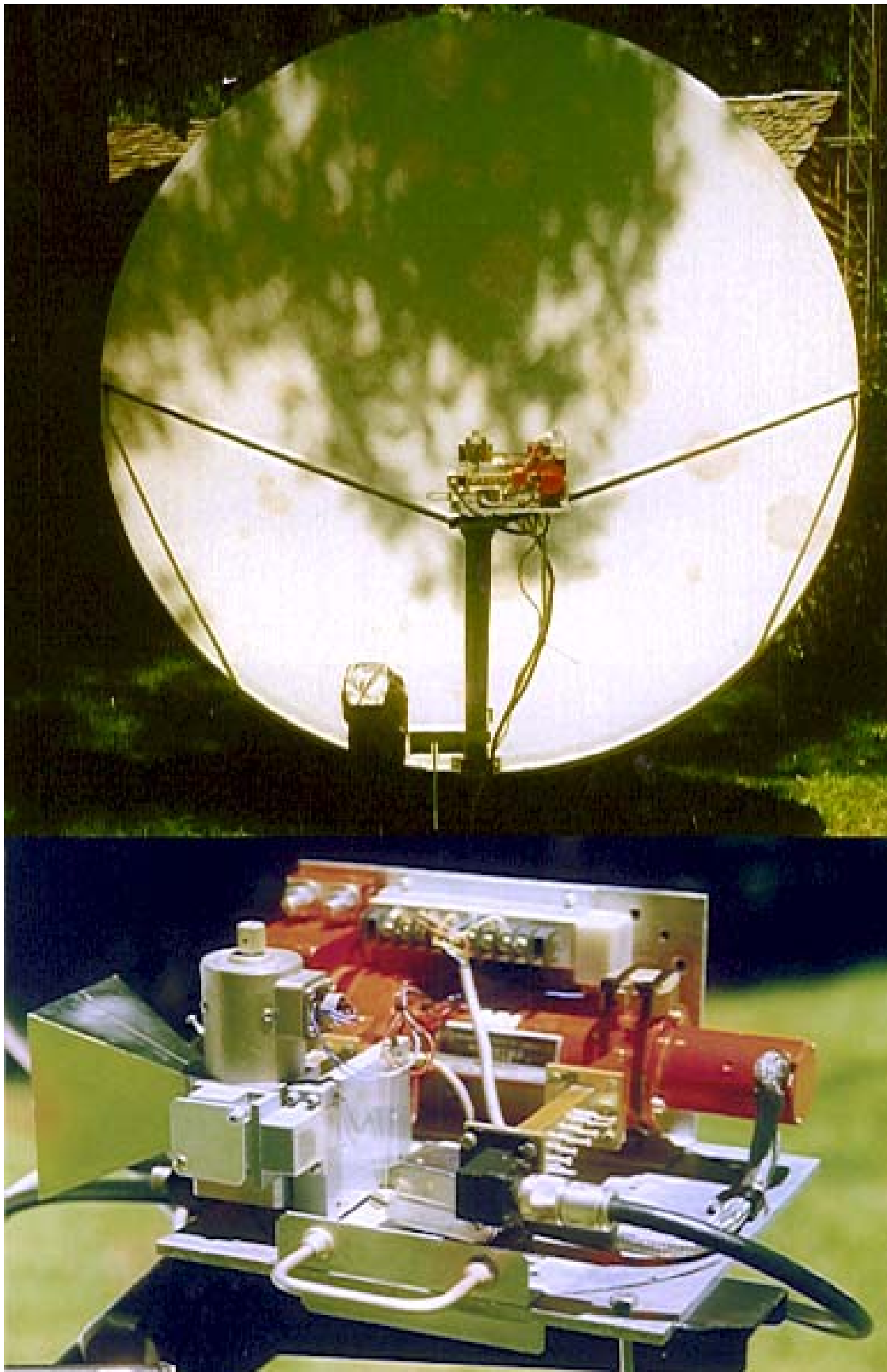

Figure 30.12

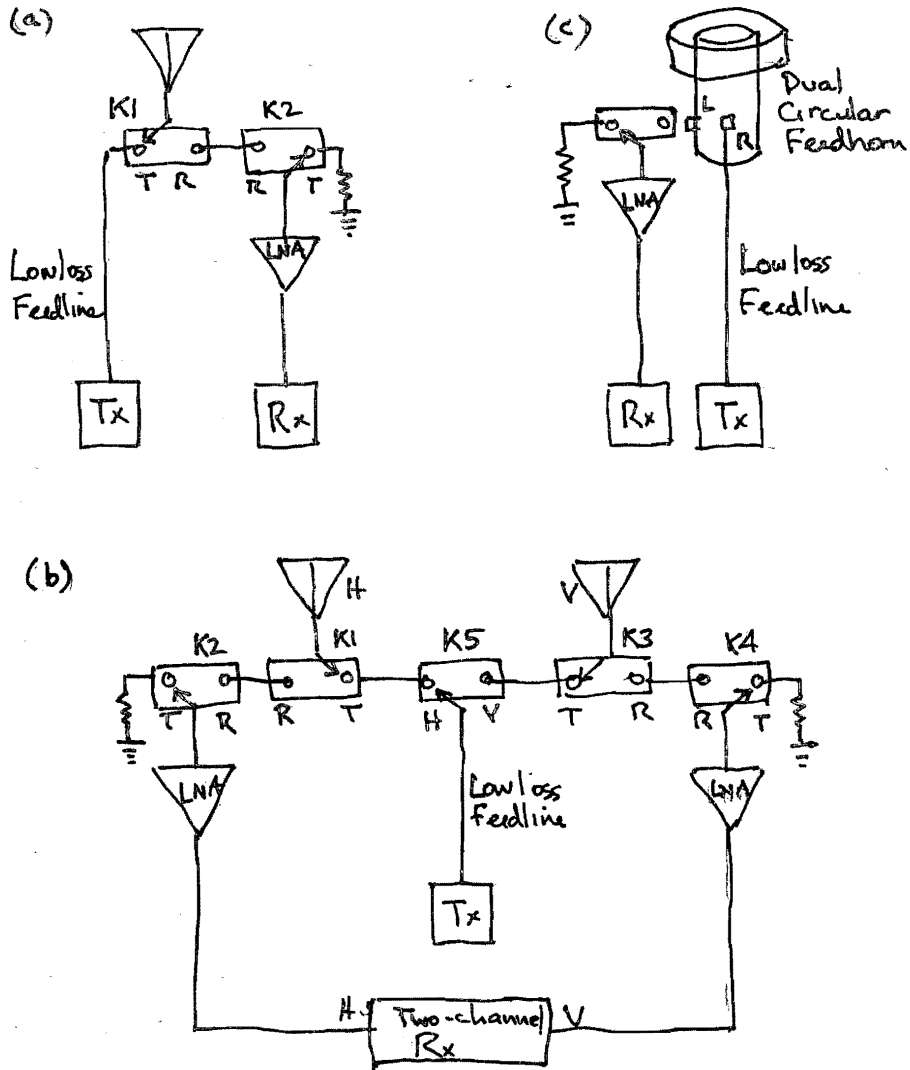

Figure 30.13

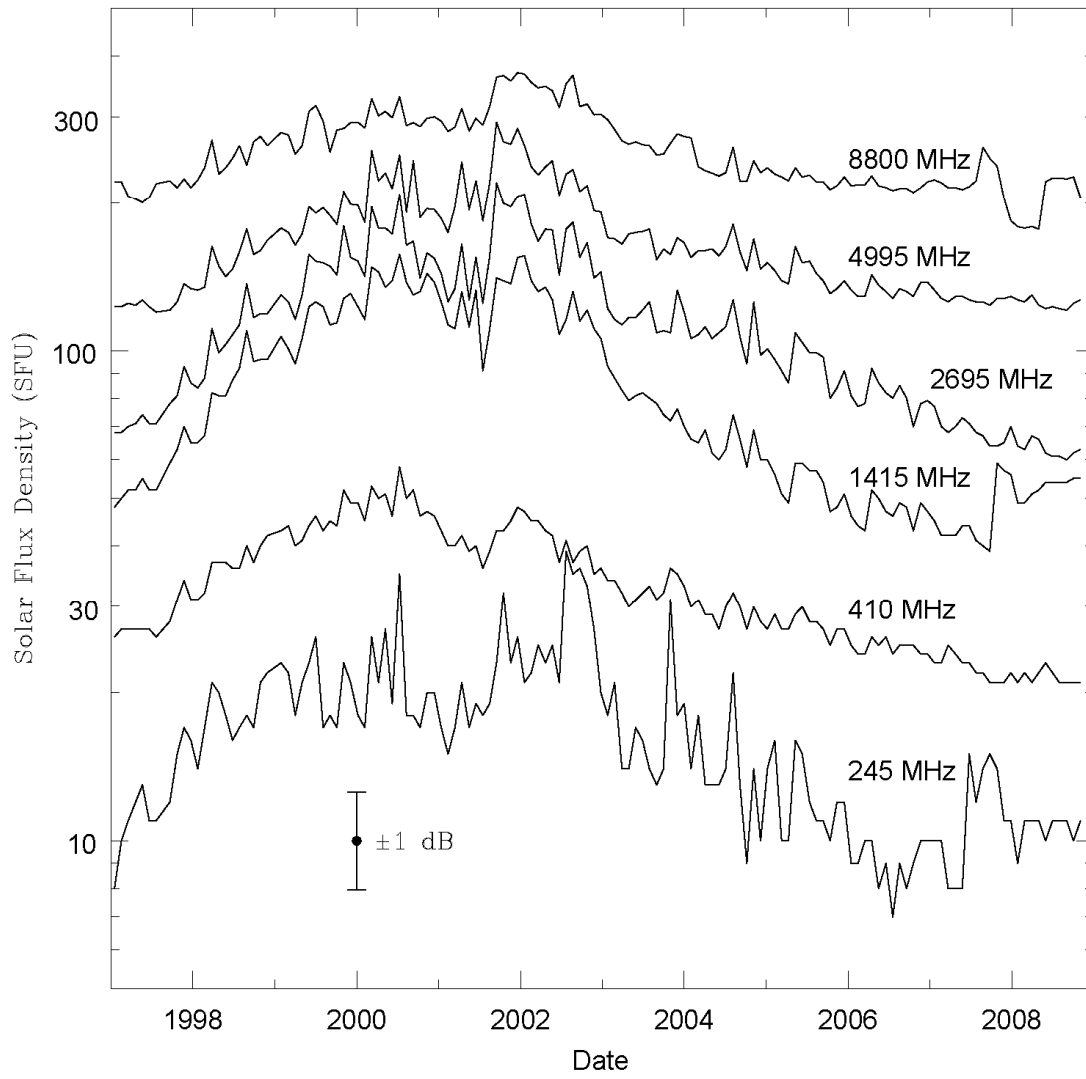

Figure 30.14

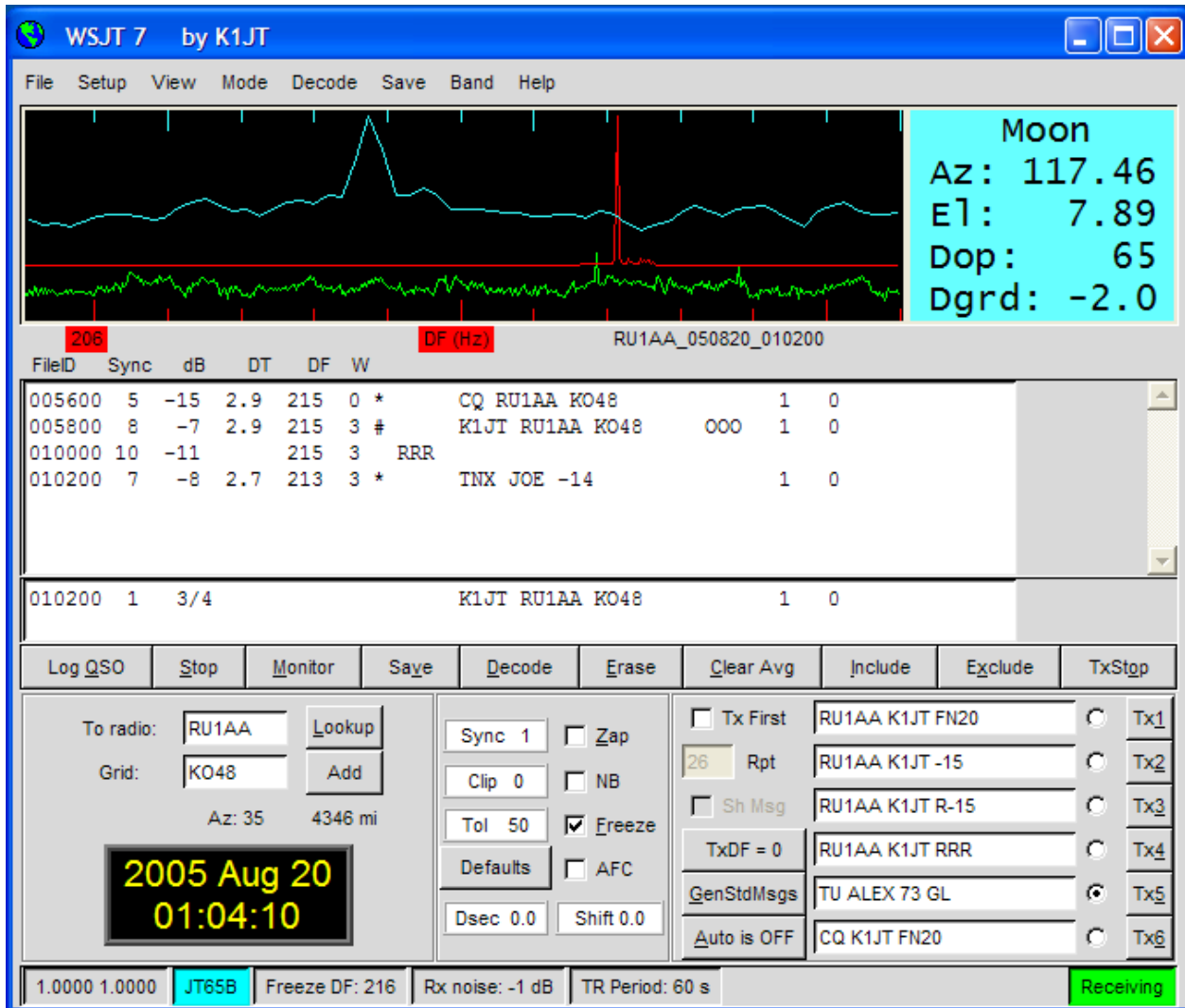

Figure 30.15