



4 Antennas as an essential part of any radio station

4.1 Choosing an antenna

Communicators quickly learn two antenna truths:

- **Any antenna is better than no antenna.**
- Time, effort and money invested in the antenna system generally will provide more improvement to communications than an equal investment to any other part of the station.

The antenna converts electrical energy to radio waves and radio waves to electrical energy, which makes two-way radio communication possible with just one antenna.

Success in communicating depends heavily on an antenna. A good antenna can make a fair receiver perform well. It can also make a few watts sound like much more. Since the same antenna is used to transmit and receive, any improvements to the antenna make the signal stronger at the desired reception points. Some antennas work better than others. It is useful to experiment with different antenna types.

4.2 Antenna system considerations

4.2.4 Tuning the antenna

The antenna length given by an equation is just an approximation. Nearby trees, buildings or large metal objects and height above ground all affect the resonant frequency of an antenna. An SWR meter can help to determine if the antenna should be shortened or lengthened. The correct length provides the best impedance match for the transmitter.

After cutting the wire to the length given by the equation, the tuning of the antenna should be adjusted for the best operation. With the antenna in its final location, the SWR should be observed at various frequencies within the desired band. If the SWR is much higher at the low-frequency end of the band the antenna is too short. If the antenna is too short, an extra length of wire can be attached to each end with an alligator clip. Then the extra length can be shortened a little at a time until the correct length is reached. If the SWR is much higher at the high-frequency end of the band, the antenna is too long. When the antenna is properly tuned, the lowest SWR values should be around the preferred operating frequency.

4.2.5 Transmission lines

The most commonly used type of antenna system transmission line is the coaxial cable (“coax”), where one conductor is inside the other. Coaxial cable has several advantages: It is readily available and resistant to weather. It can be buried in the ground if necessary, bent, coiled and run adjacent to metal with little effect.

Most common HF antennas are designed for use with transmission lines having characteristic impedances of about 50 ohms. RG-8, RG-58, RG-174 and RG-213 are commonly used coaxial cables. RG-8 and RG-213 are similar cables, and they have the least loss of the types listed here. The larger coax types (RG-8, RG-213, RG-11) have less signal loss than the smaller types. If the feed line is less than 30 meters long, the small additional signal loss on the HF bands is negligible. On VHF/UHF bands losses are more noticeable, especially when the feed line is long. On these bands, higher-quality RG-213 coax or even lower-loss rigid or semi-rigid coaxial cables minimise losses for transmission lines exceeding 30 meters.

Coaxial cable connectors are an important part of a coaxial feed line. It is prudent to check the coaxial connectors periodically to see that they are clean and tight to minimise any losses. If a bad solder connection is suspected, the joints should be cleaned and re-soldered. The choice of connectors normally depends on matching connectors on the radios. Many HF radios and many VHF radios use SO-239 connectors. The mating connector is a PL-259 (Figure 7). The PL-259 is sometimes called a UHF connector, although constant impedance connectors such as Type-N the best choice for the UHF bands. PL-259 connectors are designed for use with RG-8 or RG-213 cables.



When using coax to connect the transmission line, an SO-239 connector should terminate the line at the centre insulator and a PL-259 should be used at the end connecting to the radio.

Figure – PL-259 coaxial connector

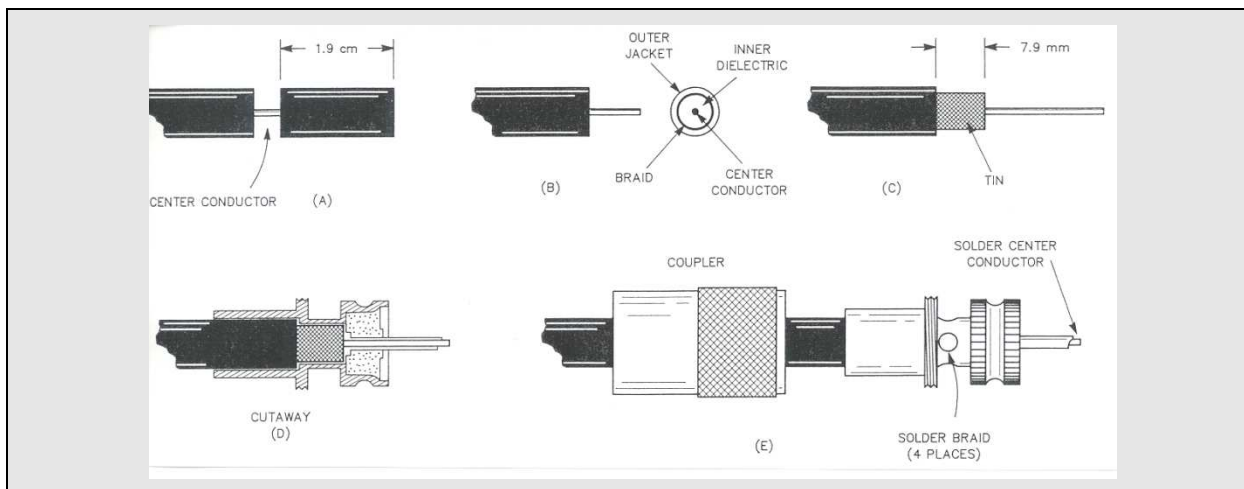

4.2.6 Matching impedances within the antenna system

If an antenna system does not match the characteristic impedance of the transmitter, some of the power is reflected back from the antenna to the transmitter. When this happens, the RF voltage and current are not uniform along the line. The power travelling from the transmitter to the antenna is called forward power and is radiated from the antenna. The standing-wave ratio (SWR) is the ratio of the maximum voltage on the line to the minimum voltage. An SWR meter measures the relative impedance match between an antenna and its feed line. Lower SWR values mean a better impedance match exists between the transmitter and the antenna system. If a perfect match exists, the SWR is 1:1. The SWR defines the quality of an antenna as seen from the transmitter, but a low SWR does not guarantee that the antenna will radiate the RF energy supplied to it by the transmitter. An SWR measurement of 2:1 indicates a fairly good impedance match.

4.2.7 SWR meters

The most common SWR meter application is tuning an antenna to resonate on a given frequency. An SWR reading of 2:1 or less is quite acceptable. A reading of 4:1 or more is unacceptable. This means there is a serious impedance mismatch between the transmitter, the antenna or the feed line.

How the SWR is measured depends on the type of meter. Some SWR meters have a SENSITIVITY control and a FORWARD-REFLECTED switch. If so, the meter scale usually provides a direct SWR reading. To use the meter, first put the switch in the FORWARD position. Then adjust the SENSITIVITY control and the transmitter power output until the meter reads full scale. Some meters have a mark on the meter face labelled SET or CAL. The meter pointer should rest on this mark. Next, set the selector switch to the REFLECTED position. This should be done without readjusting the transmitter power or the meter SENSITIVITY control. Now the meter pointer displays the SWR value. Find the resonant frequency of an antenna by connecting the meter between the feed line and your antenna. This technique will measure the relative impedance match between the antenna and its feed line. The settings that provide the lowest SWR at the operating frequency are preferred.

4.3 Practical antennas

4.3.1 The half-wave dipole antenna

Probably the most common HF antenna is a wire cut to a half wavelength ($\frac{1}{2} \lambda$) at the operating frequency. The transmission line attaches across an insulator at the centre of the wire. This is the half-wave dipole. This is often referred to as a dipole antenna. (*Di* means two, so a dipole has two equal parts. A dipole could be a length other



than $\frac{1}{2} \lambda$.) The total length of a half-wavelength dipole is $\frac{1}{2} \lambda$. The feed line connects to the centre. This means that each side of this dipole is $\frac{1}{4} \lambda$ long.

Wavelength in space can be determined by dividing the constant 300 by the frequency in megahertz (MHz). For example, at 15 MHz, the wavelength is $300/15 = 20$ meters.

Radio signals travel slower in wire than in air, thus the following equation may be used to find the total length of a $\frac{1}{2} \lambda$ dipole for a specific frequency. Notice that the frequency is given in megahertz and the antenna length is in meters for this equation:

$$L \text{ (in meters)} = \frac{143}{f_{\text{MHz}}}$$

This equation also takes into account other factors, often called *antenna effects*. It gives the approximate length of wire for an HF dipole antenna. The equation will not be as accurate for VHF/UHF antennas. The element diameter is a larger percentage of the wavelength at VHF and higher frequencies. Other effects, such as *end effects* also make the equation less accurate at VHF and UHF.

Table 2 – Approximate lengths for $\frac{1}{2} \lambda$ dipoles suitable for fixed, mobile and amateur bands

Frequency (MHz)	Length (m)	Frequency (MHz)	Length (m)	Frequency (MHz)	Length (m)
3.3	43.3	12.2	11.7	30	4.8
3.5	40.8	13.4	10.7	35	4.1
3.8	37.6	13.9	10.3	40	3.6
4.5	31.8	14.2	10.0	50	2.86
4.9	29.2	14.6	9.8	145	99 cm
5.2	27.5	16.0	8.8	150	95
5.8	24.6	17.4	8.2	155	92
6.8	21.0	18.1	7.9	160	89
7.1	20.1	20.0	7.1	165	87
7.7	18.6	21.2	6.7	170	84
9.2	15.5	21.8	6.5	435	33
9.9	14.4	23.8	6.0	450	32
10.1	14.1	24.9	5.7	455	31.4
10.6	13.5	25.3	5.6	460	31
11.5	12.4	29.0	4.9	465	30.7



Figure – Construction of a simple half-wave dipole antenna. At top is the basic dipole assembly. Bottom left shows how to connect wire ends to insulators. Bottom right illustrates connection of the transmission line to the centre of the dipole

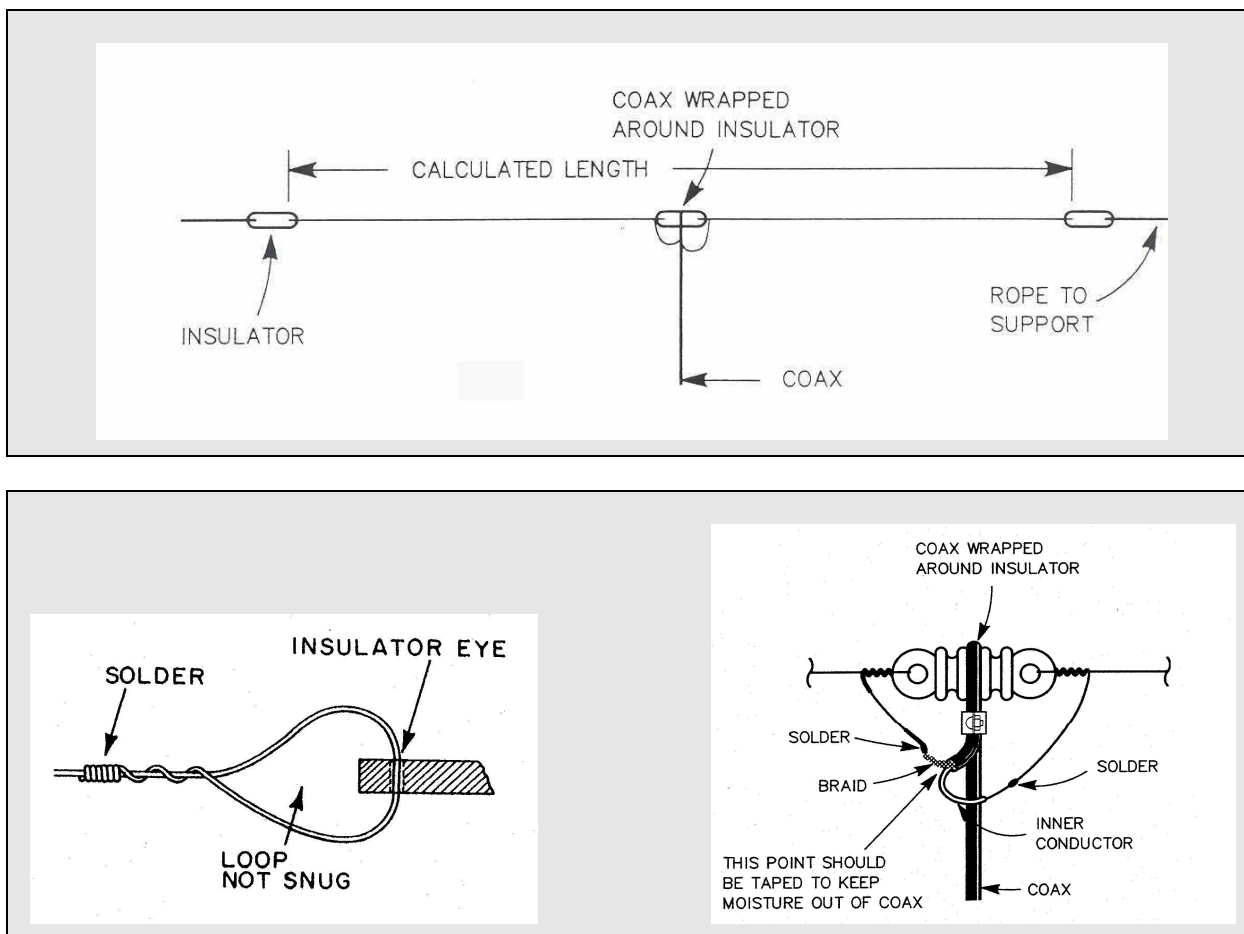

Household electrical wire and stranded wire will stretch with time; a heavy gauge copper-clad steel wire does not stretch as much. The dipole should be cut according to the dimension found by the equation above (total length of a $\frac{1}{2} \lambda$ dipole), but a little extra length should be provided to wrap the ends around the insulators. A coaxial or parallel transmission line is needed to connect the antenna to the transmitter. Three insulators are also needed. If supporting the antenna in the middle, both ends will droop toward the ground. This antenna, known as an inverted-V dipole, is almost omni-directional and works best when the angle between the wires is equal to or greater than 90° . A dipole can also be supported only at one end, in which case it is known as a sloping dipole.

Dipole antennas radiate best in a direction that is 90° to the antenna wire. For example, suppose a dipole antenna is installed so the ends of the wire run in an east/west direction. Assuming it was sufficiently above the ground (for example, $\frac{1}{2} \lambda$ high), this antenna would send stronger signals in north and south directions. A dipole also sends radio energy straight up and straight down. Of course, the dipole also emits some energy in directions off the ends of the wire, but these signals will be attenuated. Though it is possible to contact stations to the east and west with this antenna, signals are stronger with stations to the north and south.



Figure 10 – Alternative ways of installing a dipole. The configuration on the left is an Inverted-V dipole. A sloping dipole is shown at right. A balun (not shown) may be used at the feed point, as this is a balanced antenna

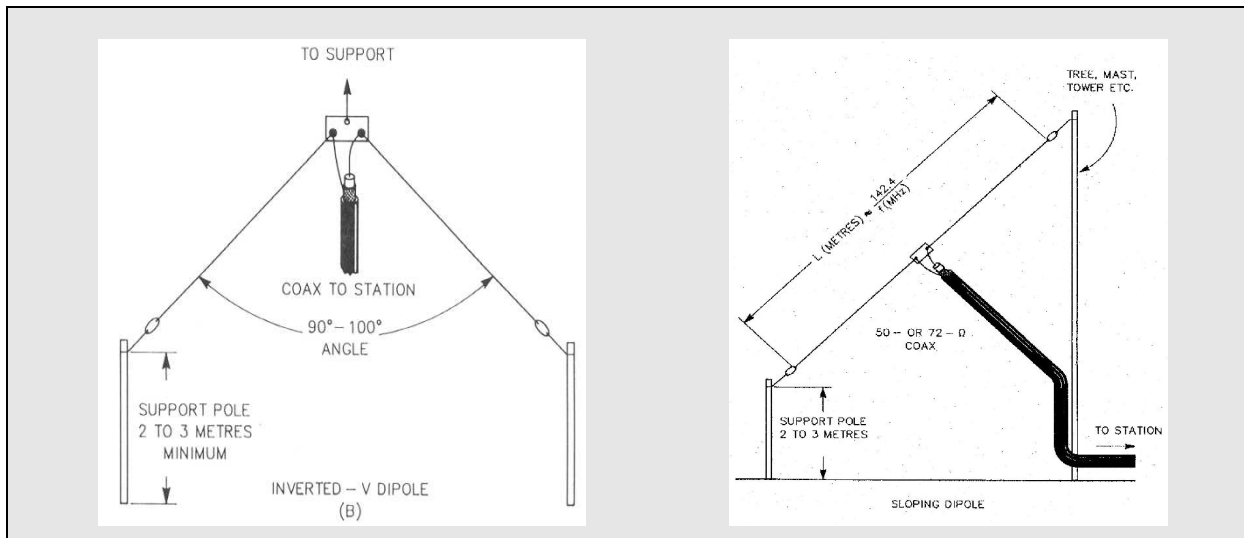

4.3.2 Broadband folded dipole

A broadband version of the dipole, the folded dipole has an impedance of about 300 ohms and can be fed directly with any length of 300 ohm feed line. This variation of the dipole is termed *broadband* because it offers a better match to the feeder over a somewhat wider range of frequencies. When a folded dipole is installed as an inverted “V” it is essentially omni-directional. There are several broadband folded dipoles available commercially that provide acceptable HF performance, even when operating without a tuner.

4.3.3 Quarter-wavelength vertical antenna

The quarter-wavelength vertical antenna is effective and easy to build. It requires only one element and one support. On the HF bands it is often used for long distance communications. Vertical antennas are referred to as non-directional or omni-directional antennas because they send radio energy equally well in all compass directions. They also tend to concentrate the signals toward the horizon as they have a low-angle radiation pattern and do not generally radiate strong signals upward.

Figure 11 shows how to construct a simple vertical antenna. This vertical antenna has a radiator that is $\frac{1}{4} \lambda$ long. Use the following equation to find the approximate length for the radiator. The frequency is given in megahertz and the length is in meters in this equation.

$$L \text{ (in meters)} = \frac{71}{f_{\text{MHz}}}$$



Figure 11 – Simple quarter-wave vertical antenna

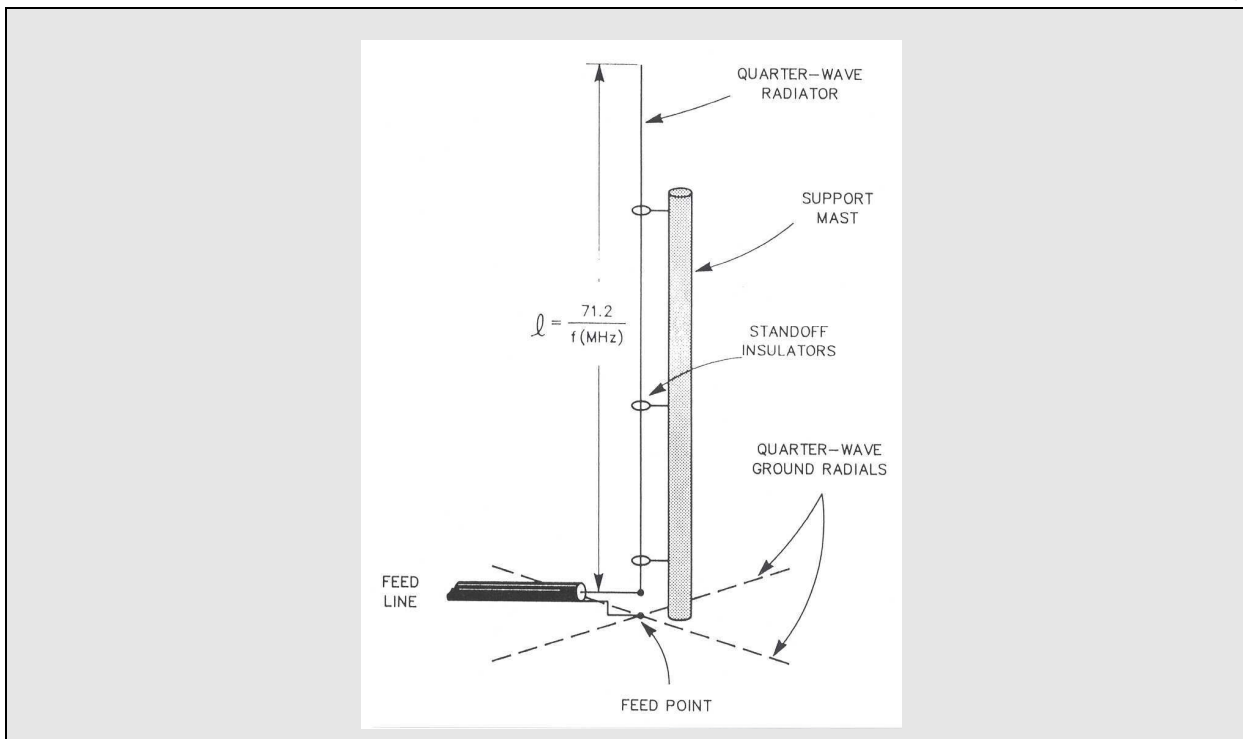

Table 3 – Approximate lengths for ¼ λ monopoles and ground radials suitable for fixed, mobile and amateur bands

Frequency (MHz)	Length (m)
3.3	21.6
3.5	20.4
3.8	18.8
4.5	15.9
4.9	14.6
5.2	13.7
5.8	12.3
6.8	10.5
7.1	10.0
7.7	9.3
9.2	7.7
9.9	7.2
10.1	7.1
10.6	6.7
11.5	6.2

Frequency (MHz)	Length (m)
12.2	5.9
13.4	5.3
13.9	5.1
14.2	5.0
14.6	4.9
16.0	4.5
17.4	4.1
18.1	3.9
20.0	3.5
21.2	3.3
21.8	3.2
23.8	3.0
24.9	2.9
25.3	2.8
29.0	2.5

Frequency (MHz)	Length (m)
30	2.4
35	2.1
40	1.8
50	1.43
145	50 cm
150	48
155	46
160	44
165	43
170	42
435	117
450	16
455	16
460	16
465	15



For successful results, the $\frac{1}{4} \lambda$ vertical should have a radial system to reduce Earth losses and to act as a ground plane. For operation on high frequencies, the vertical may be at ground level and the radials placed on the ground. At least 3 radials should be used and out like the spokes of a wheel, with the vertical at the centre. Radials should be at least $\frac{1}{4} \lambda$ long or more at the lowest operating frequency.

Most vertical antennas used at HF are $\frac{1}{4} \lambda$ long or shorter with appropriate loading networks. For VHF and UHF, antennas are physically short enough that longer verticals may be used. A popular mobile antenna is a $\frac{5}{8} \lambda$ vertical, often called a “five-eighths whip”. This antenna is popular because it concentrates more of the radio energy toward the horizon than a $\frac{1}{4} \lambda$ vertical.

Commercially available vertical antennas need a coax feed line, usually with a PL-259 connector. Just as with the dipole antenna, RG-8, RG-11 or RG-58 coax can be used.

Some manufacturers offer multi-band vertical antennas that use series-tuned circuits (traps) to make the antenna resonant at different frequencies.

To fabricate a tree-mounted HF ground plane antenna (Figure 12), a length of RG-58 cable is connected to the feed point of the antenna and is attached to an insulator. The radial wires are soldered to the coax-line braid at this point. The top of the radiator section is suspended from a tree limb or other convenient support, and in turn supports the rest of the antenna.

Figure 12 – Construction of tree-mounted ground plane antenna. $L = 143/f_{\text{MHz}}$

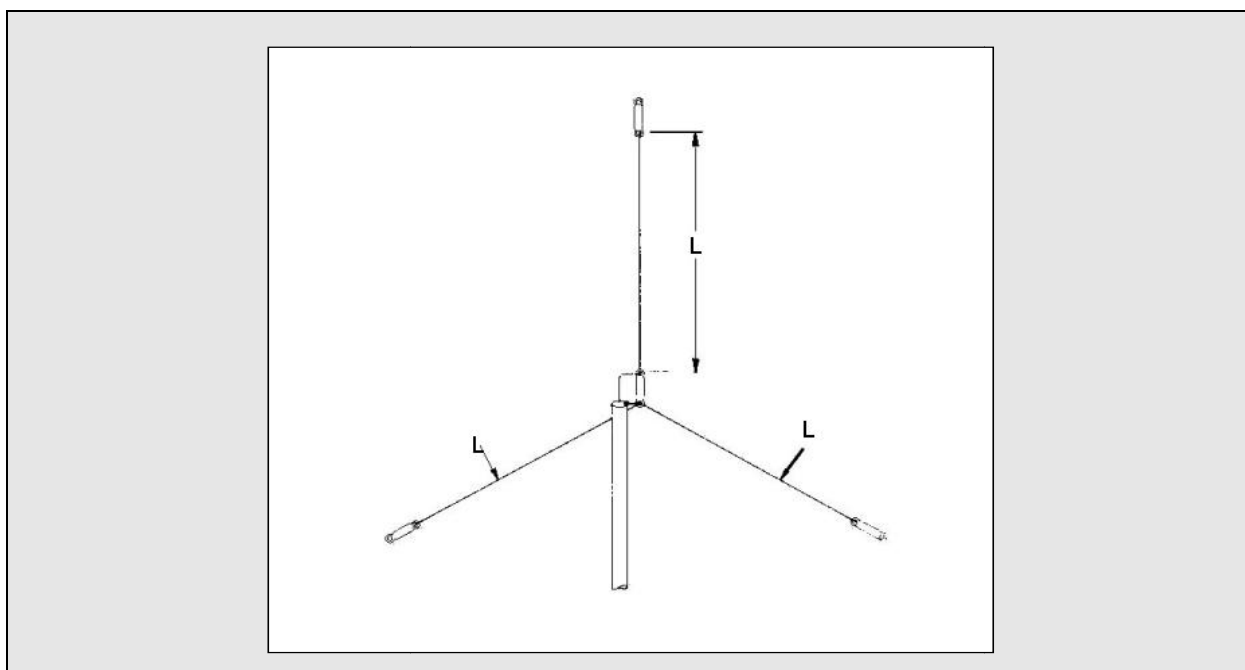

The dimensions for the antenna are the same as for a $\frac{1}{4} \lambda$ vertical antenna. All three wires of the antenna are $\frac{1}{4} \lambda$ long. This generally limits the usefulness of the antenna to 7 MHz and higher bands, as temporary supports higher than 10 or 15 meters may not be available.

4.3.4 Antennas for hand-held transceivers

VHF and UHF hand-held transceivers normally use shortened flexible antennas that are inexpensive, small, lightweight and robust. On the other hand, they have some disadvantages: It is a compromise design that is inefficient and thus does not perform as well as larger antennas. Two better-performing antennas are the $\frac{1}{4} \lambda$ and the $\frac{5}{8} \lambda$ telescoping types that are available as separate accessories.



4.3.5 Vertical antennas for VHF and UHF

For operation of stations at fixed locations, the $\frac{1}{4} \lambda$ vertical is an ideal choice. The 145 MHz model shown in Figure 13 uses a flat piece of sheet aluminium, to which radials are connected with machine screws. A 45° bend is made in each of the radials. This bend can be made with an ordinary bench vise. An SO-239 chassis connector is mounted at the centre of the aluminium plate with the threaded part of the connector facing down. The vertical portion of the antenna is made of 10 mm copper wire soldered directly to the centre pin of the SO-239 connector.

Figure 13 – A VHF or UHF ground plane antenna with 4 drooping radials. $L = 143/f_{\text{MHz}}$

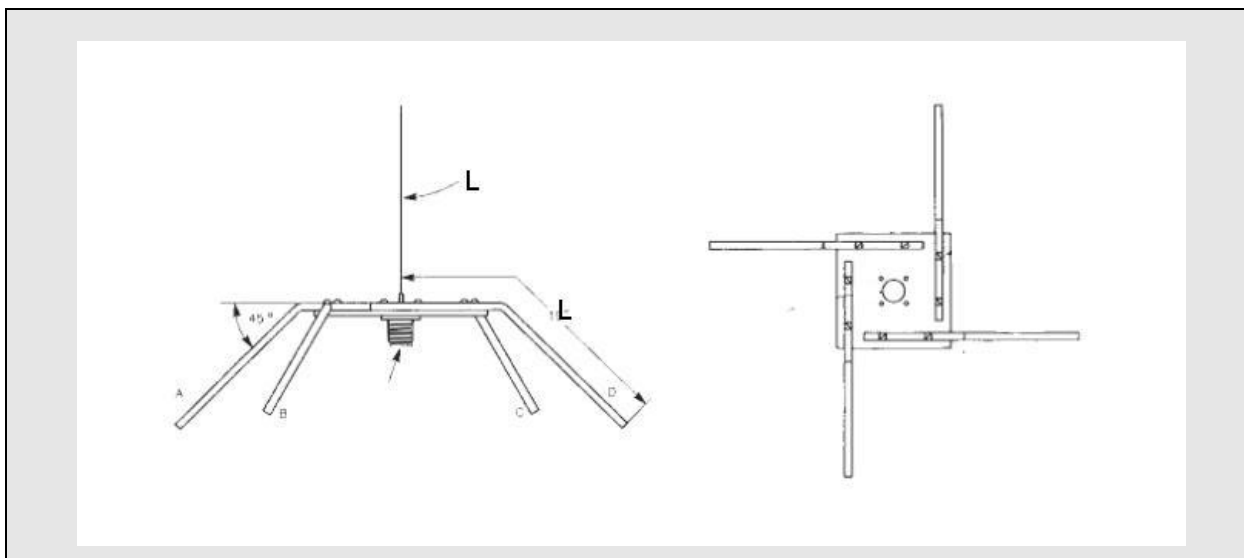

Construction is simple as it requires nothing more than an SO-239 connector and some common hardware. A small loop formed at the inside end of each radial is used to attach the radial directly to the mounting holes of the coaxial connector. After the radial is fastened to the SO-239 with hardware, a large soldering iron or propane torch is used to solder the radial and the mounting hardware to the coaxial connector. The radials are bent to a 45° angle and the vertical portion is soldered to the centre pin to complete the antenna. It is prudent to apply a small amount of sealant around the areas of the centre pin of the connector to prevent the entry of water into the connector and coax line.

4.3.6 Delta loop

The Delta loop is another field expedient wire antenna used by disaster relief organisations. There are three key advantages to a Delta loop antenna: 1) a ground plane is unnecessary; 2) a full-wave loop (depending on the shape) has some gain over a dipole; and 3) a closed loop is a “quieter” (improved signal-to-noise ratio) receiving antenna than are most vertical and some horizontal antennas. Feed point selection will permit the choice of vertical or horizontal polarisation. Various angles of radiation will result from assorted feed-point selections. The system is rather flexible and is capable of maximising close in or long distance communications (high angle versus low angle). Figure 14 illustrates various configurations that can be used. The bandwidth at resonance is similar to a dipole. An antenna-tuning unit (ATU) is recommended for matching the system to the transmitter in parts of the band where the SWR is high. There is no rule that dictates the shape of a full wave loop. It may be convenient to use a triangular shape with the apex is at the top in which case only one high support is needed. Circular, square or rectangular shapes have been used.



Figure 14 – Various configurations for a full-wavelength Delta loop antenna. Overall length of the antenna wire is approximately $286/f_{\text{MHz}}$

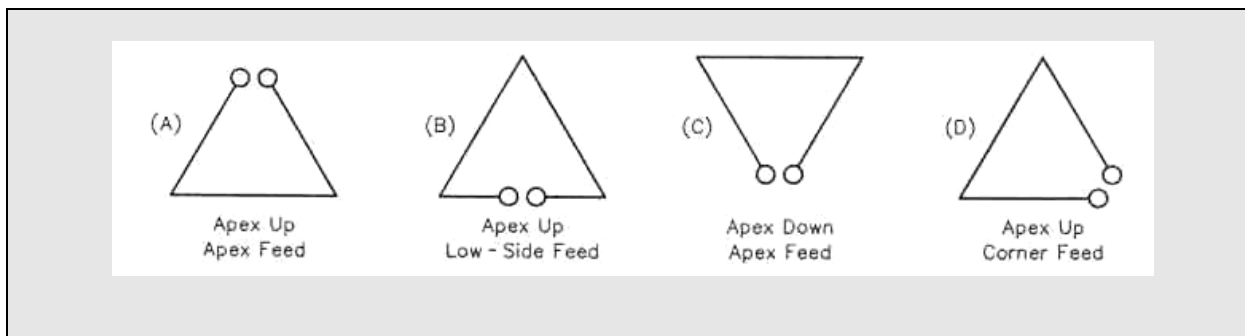

Configuration	A	B	C	D
Polarisation	Horizontal	Horizontal	Horizontal	Vertical
Radiation angle	Moderately high	High	Moderately high	Low

4.3.7 Directional antennas

Directional antennas have two important advantages over simpler omni-directional antennas such as dipoles and vertical monopoles. As transmitting antennas, they concentrate most of the radiation in one direction. For receiving, directional antennas can be pointed toward the desired direction or away from a source of noise.

Although generally large and expensive below about 10 MHz, directional antennas often are used on the upper high frequency bands, such as from 10 MHz to 30 MHz. Directional antennas commonly used at VHF and UHF owing to their reasonably small size. The most common directional antenna is the *Yagi* antenna, but there are other types, as well.

A Yagi antenna has several elements attached to a central *boom*, as Figure 15 shows. The elements are parallel to each other and are placed in a straight line along the boom. Although several factors affect the amount of gain of a Yagi antenna, *boom length* has the largest effect: The longer the boom, the higher the gain.

The transmission line connects only to one element called the *driven element*. On a three-element Yagi like the one shown in Figure 15, the driven element is in the middle. The element at the front of the antenna (toward the favoured direction) is a director. Behind the driven element is the reflector element. The driven element is about $\frac{1}{2} \lambda$ long at the antenna design frequency. The director is a bit shorter than $\frac{1}{2} \lambda$, and the reflector a bit longer. Yagi beams can have more than three elements, usually by adding more directors. Directors and reflectors are called parasitic elements, since they are not fed directly.

Communication in different directions may be achieved by turning the array using a rotator in the azimuthal (horizontal) plane, to point it in different directions.



Figure 15 – A three-element Yagi showing the reflector, driven element and director supported by a boom

